

ANNOUNCING THE NEW "C" MODEL COMPACTOR/DRIVERS

NPK is pleased to announce our newest "C" Model Compactor/Drivers. We have replaced our entire Compactor/Driver line with these new models. In addition, we have added the all new C-10C to make our line the most comprehensive in the industry. These new models have several new design features that will improve reliability as well as new options that will make them more versatile and increase productivity. *One of the new standard features developed by NPK is the patented oil bath bearing system that eliminates the need for routine greasing.*

Old Models	New "C" Models
C-2	C-2C
C-4B	C-4C
C-6B	C-6C
C-8B	C-8C
-	C-10C
C-12	C-12C

Key Features, Benefits and New Options

This drawing explains some of the key features and improvements as well as the new options.

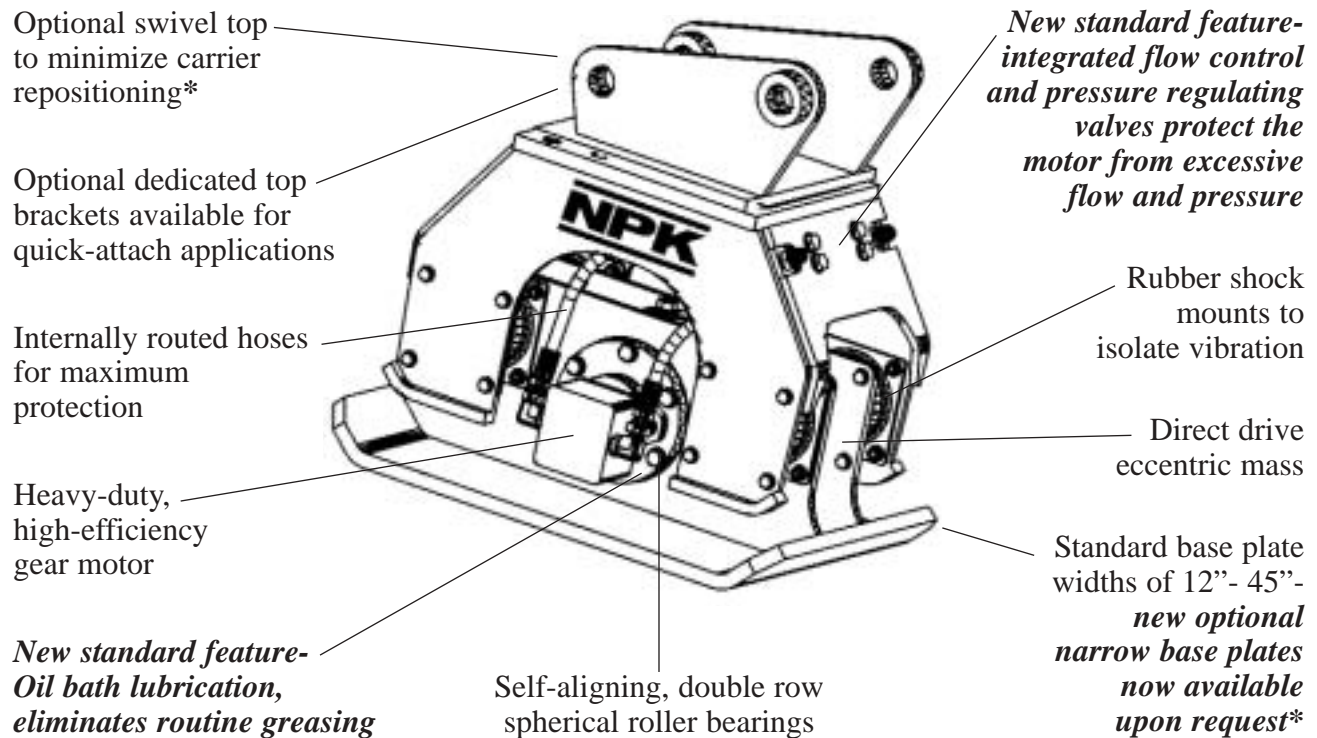

* Not available on the Model C-2C