

# NPK



## **Heavy Duty Grapples**



- **Unique Adapter Bracket Design Provides Exact OEM Dimensions for Maximum Travel, Power and Interchangeability Between Carriers in the Same Weight Class**
- **Box-Type Construction for Maximum Strength**
- **Abrasion-Resistant Steel Replacement Tips**
- **Two-into-Three Tine Configuration**

***NPK ATTACHMENTS...designed, built and backed by NPK.***



# HEAVY DUTY MECHANICAL GRAPPLES

**Engineered and manufactured to world-class standards, delivering optimum productivity for the most demanding applications**

NPK Grapples are designed to take the toughest jobs in stride: demolition, scrap yards, land clearing, recycling, rock handling and truck loading.

### Box-type construction for maximum strength and rigidity

NPK's four models offer excellent heavy-duty strength for their class and weight. Internal reinforcement adds to their structural integrity.

### Heavy-duty, abrasion-resistant steel replacement tips

In the closed position, these tips form a large surface for denser, more efficient compacting - increasing load capacity.

### Versatile two-into-three tine configuration

Rugged grapple design makes the most of your excavating tasks while the box type construction stands up to the toughest conditions.

### Unique adapter bracket

No longer are you required to dedicate a single machine for grapple work. Use of the adapter bracket allows interchangeability with machines in the same weight class.

NPK Model	Excavator Class	Specifications					
		Weight	Height	Jaw Open	Jaw Closed	Moving Jaw Width	Fixed Jaw Width
	(tons)	(lb-kg)	(in-mm)	(in-mm)	(in-mm)	(in-mm)	(in-mm)
<b>GR-2025</b>	20	2,900 lb 1,317 kg	54.5" 1,384mm	99" 2,515mm	10" 254mm	26" 660mm	44.5" 1,130mm
<b>GR-2530</b>	25	3,435 lb 1,559 kg	64.5" 1,638mm	113" 2,870mm	10" 254mm	27" 686mm	44.5" 1,130mm
<b>GR-3040</b>	30	4,800 lb 2,179 kg	69.5" 1,765mm	116" 2,946mm	10" 254mm	32" 813mm	48" 1,219mm
<b>GR-4055*</b>	45	5,700 lb 2,588 kg	75" 1,905mm	140" 3,556mm	15" 381mm	34" 864mm	52" 1,321mm

\*NPK Model 4055 not available in adapter bracket design. Specifications subject to change without notice.



*Adapter bracket design provides exact OEM dimensions for maximum travel, power and interchangeability between excavators in the same weight class.*

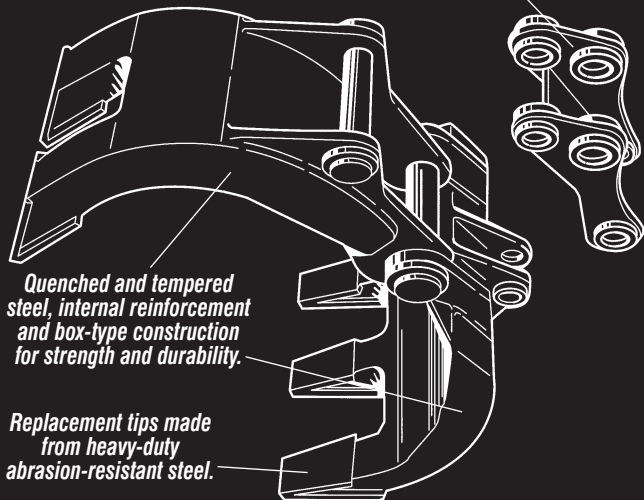

*Quenched and tempered steel, internal reinforcement and box-type construction for strength and durability.*

*Replacement tips made from heavy-duty abrasion-resistant steel.*



**NPK Construction Equipment, Inc.**  
7550 Independence Drive  
Walton Hills, OH 44146-5541  
Phone (440) 232-7900  
Toll-free (800) 225-4379  
Fax (440) 232-4382  
Internet: [www.npkce.com](http://www.npkce.com)

Sold and Serviced by:

Each product sold by NPK is subject to an express written warranty. NPK makes no other warranty, express or implied, including any warranty of merchantability of fitness for any particular purpose. NPK is not liable for any incidental or consequential damages.