



# DEMOLITION GRAB INSTRUCTION MANUAL

*MODELS:*

<i>DG-4</i>	<i>DG-6</i>	<i>DG-9</i>	<i>DG-14</i>
<i>DG-16</i>	<i>DG-20/20A</i>	<i>DG-25</i>	
<i>DG-30/30A</i>	<i>DG-40/40A</i>	<i>DG-50</i>	

*“Use Genuine NPK Parts”*

**NPK** *...attachments;  
designed, built  
and backed by NPK.*

7550 Independence Drive  
Walton Hills, OH 44146-5541  
Phone (440) 232-7900  
Fax (440) 232-6294

# CONTENTS

---

SAFETY .....	2
OPERATION .....	3
MAINTENANCE .....	4
INTRODUCTION.....	6
EXCAVATOR COMPATIBILITY .....	6
SERIAL NUMBER LOCATION .....	7
SPECIFICATIONS .....	8
HYDRAULIC INSTALLATION.....	18
HYDRAULIC LINES .....	18
SHUT-OFF VALVES .....	18
PORT CONNECTION DIAGRAM .....	19
DEMOLITION GRAB HYDRAULIC CIRCUITS.....	20
MOUNTING INSTALLATION.....	23
MOUNTING TO THE EXCAVATOR .....	24
REMOVAL FROM THE CARRIER.....	24
STORAGE OF DEMOLITION GRAB .....	24
OPERATING INSTRUCTIONS.....	25
OPERATING TECHNIQUES AND PRECAUTIONS.....	27
GENERAL MAINTENANCE.....	30
DAILY INSPECTION AND MAINTENANCE .....	30
ARM MAINTENANCE .....	31
FRAME MAINTENANCE.....	31
FRAME CRACK REPAIR.....	31
LUBRICATION POINTS.....	32
SLEWING RING INSPECTION AND MAINTENANCE .....	33
MEASURING MAXIMUM AXIAL MOVEMENT .....	33
NPK ASSEMBLY LUBRICANT .....	34
ROTARY JOINT MAINTENANCE .....	35
HYDRAULIC ROTARY JOINT ASSEMBLY.....	35
LEAKAGE OF THE SEALS.....	35
TESTING THE ROTARY JOINT SEALS FOR INTERNAL LEAKAGE .....	35
REPLACEMENT OF THE SEALS IN THE ROTARY JOINT .....	36
TROUBLESHOOTING .....	40
DETERMINE THE TYPE OF PROBLEM.....	40
MEASURING OPERATING PRESSURES .....	40
RELIEF VALVE CHECKING AND SETTING PROCEDURE.....	40
COUNTERBALANCE VALVE LOCATION.....	42
TROUBLESHOOTING CHART FOR LOW POWER .....	43
CHECKING HYDRAULIC FLOW AT RATED PRESSURE .....	44
PROCEDURE FOR CHECKING HYDRAULIC FLOW AT RATED PRESSURE .....	44
TROUBLESHOOTING CHART FOR SLOW CYLINDER SPEED.....	46
JAW DRIFT .....	46
TO DETERMINE IF THE JAW DRIFT IS OCCURRING FROM A BAD CYLINDER OR THE CARRIER .....	46
ROTATION .....	47
MEASURING ROTATION PRESSURES.....	47
ROTATION PRESSURE CHECKING PROCEDURE.....	48
TROUBLESHOOTING CHART FOR ROTATION .....	48
FASTENER TORQUE CHARTS .....	50
PINION GEAR INSTALLATION.....	54
CYLINDER TORQUE SPECIFICATIONS .....	55
ROD NUT AND PISTON TORQUES .....	55
CONVERT FROM DUAL MOTOR TO SINGLE MOTOR (DG20, DG30, DG40) .....	56
KEYWORDS FOR COMMON DEMOLITION GRAB COMPONENTS .....	57
WARRANTY STATEMENTS .....	58
NOTES.....	60
SERVICE RECORD.....	60

# SAFETY

---



Safety notices in NPK Instruction Manuals follow ISO and ANSI standards for safety warnings:



DANGER (red) notices indicate an imminently hazardous situation which, if not avoided, **will result in death or serious injury**.



WARNING (orange) notices indicate a potentially hazardous situation which, if not avoided, **could result in death or serious injury**.



CAUTION (yellow) notices indicate a potentially hazardous situation, which, if not avoided, **may result in minor or moderate injury**.



ATTENTION (blue) notices in NPK Instruction Manuals are an NPK standard to alert the reader to situations which, if not avoided, **could result in equipment damage**.

---



WARNING – FALLING OR FLYING DEBRIS decals are included with each NPK Demolition Grab Attachment. The decal (**part number H100-7210**) must be installed in the cab, visible to the operator.



WARNING – STAY CLEAR decal (**part number H100-7200**) is installed on all NPK Demolition Grab Attachment. Keep them clean and visible. NPK will provide decals free of charge as needed.

# SAFETY

## OPERATION

### WARNING

1. Operator personnel must read and understand the **NPK INSTRUCTION MANUAL** to prevent serious or fatal injury.
2. **FLYING OR FALLING DEBRIS CAN CAUSE SERIOUS OR FATAL INJURY.** Keep personnel and bystanders clear of the **DEMOLITION GRAB** while in operation.
3. Do not operate **DEMOLITION GRAB** without an impact resistant shield between the **DEMOLITION GRAB** and operator. Operate with extreme caution near walls or columns that may collapse and near concrete debris that may fall.
4. Operate the **DEMOLITION GRAB** from the operator's seat only.
5. Use two people whenever operator visibility is limited, one to operate the **DEMOLITION GRAB**, the other to guide operations.
6. **Do not** leave a load suspended in air.
7. **Do not** pass a load over people, vehicles, etc.
8. **Do not** operate the **DEMOLITION GRAB** within reach of power lines.
9. **Do not** climb, sit, or ride on the **DEMOLITION GRAB**.



Warning Decal for Cab Installation

### CAUTION

10. Match the **DEMOLITION GRAB** size to excavator according to NPK recommendations, see page 6. The excavator must be stable during **DEMOLITION GRAB** operation and during transport.
11. **Do not** operate without inspection (access) covers in place.
12. Be especially cautious around hydraulic lines. Hydraulic oil can be extremely **HOT!** **Avoid skin contact with hydraulic oil. It can cause severe burns!**
13. **Protect hands and body from hydraulic fluids under pressure.** Escaping high pressure fluid can penetrate the skin, causing serious injury. Avoid the hazard by relieving pressure before disconnecting any lines. Search for leaks with a piece of cardboard, or other object. **If an accident occurs, see a doctor immediately! Hydraulic fluid injected into the skin must be surgically removed immediately or gangrene may result!**
14. Make daily visual inspections of all fasteners, boom pins, hoses, etc.
15. When removing or installing mounting pins, beware of flying metal chips.

# SAFETY

---

## MAINTENANCE



1. Use only NPK supplied replacement parts. NPK specifically disclaims any responsibility for bodily injury or Demolition Grab damage that results from the use of parts not sold or approved by NPK.
2. Use extreme caution in handling. A fully assembled Demolition Grab can weigh over 2 tons. Sub-assemblies range in weight from hundreds to thousands of pounds. To avoid bodily harm, use lifting and securing mechanisms of adequate capacity to support loads. Seek the aid of an assistant as much as possible, and always when handling heavier sub-assemblies.
3. The supplied safety bar (t79) **MUST** always be installed during transport, repairs, dismounting and mounting to the carrier, changing the cutters and all other routines at the attachment (GZ).

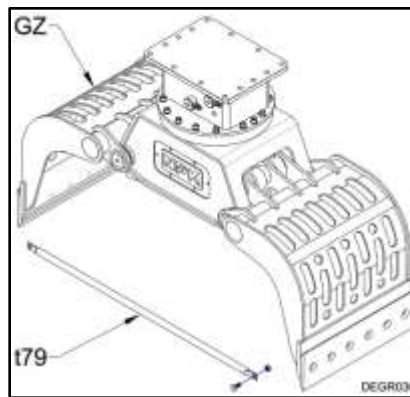

4. Wear safety glasses and protective clothing when working on the Demolition Grab. Wear thermal-protective gloves when handling heated parts.
5. Prevent exposure to hazardous fumes. Remove all paint, grease, and oil before heating, cutting or welding on the Demolition Grab.
6. Be especially cautious around hydraulic lines. Hydraulic oil can be extremely **HOT!**  
***Avoid skin contact with hydraulic oil. It can cause severe burns!***
7. **Protect hands and body from hydraulic fluids under pressure.** Escaping fluid under pressure can penetrate the skin, causing serious injury. Avoid the hazard by relieving pressure before disconnecting any lines. Search for leaks with a piece of cardboard, or other object. ***If an accident occurs, see a doctor immediately! Hydraulic fluid injected into the skin must be surgically removed within a few hours or gangrene may result.***
8. When removing or installing mounting pins, beware of flying metal chips.

# SAFETY

---

## MAINTENANCE

### STANDARD PRACTICES

#### ATTENTION

Maintenance of and repairs to the Demolition Grab should be performed by an experienced service technician, thoroughly familiar with all standard practices and procedures, and most importantly, all safety precautions. The following is a review of common standard practices to be followed when working with hydraulic equipment and is not meant to be all-inclusive. Rather, this review is presented as a reminder as to some of the unique characteristics of hydraulic equipment.

- The prevention of foreign contaminant damage is critical when working with hydraulic equipment. Protect exposed holes and parts to guard against entry of contaminants. Install metal or plastic plugs/caps where applicable to prevent entry of debris into the hydraulic system.
- Mark the location and position of mating parts as an aid to re-assembly. Mark corresponding parts uniquely to reflect their relationship, including proper location, position, orientation, and/or alignment.

#### DO:

- During assembly, observe all markings made during disassembly, and all corresponding features of mating parts to ensure proper location, position, orientation, and alignment.
- During disassembly of a sub-assembly, place removed components on a clean, dry surface, in proper relative position as an aid in re-assembly.
- Always inspect threaded areas on components. Repair or replace as required. Never apply uncured thread adhesive to a fastener that has cured adhesive on it. Clean the fastener and the threaded bore. A tap and die may be helpful for this task. Be sure to remove loose debris from the threaded bore.
- Use care to avoid scratches, nicks, dents, or other damage to machined surfaces of mating components.
- When securing a component, always tighten cap screws gradually in an opposing pattern, applying the specified torque.
- Grease can be used to temporarily hold a part in place while the abutting part is placed into position.
- Always use common sense and exercise standard safety precautions when working with all tools and equipment required to maintain, repair or troubleshoot the Demolition Grab.

# INTRODUCTION

---

NPK prides itself on the design and manufacture of high-quality products. This tradition of quality workmanship and materials continues in our Demolition Grab. Many years of productive service can be realized with proper operation and care of the Demolition Grab.

The purpose of this manual is to provide you with the information and instructions required to properly operate and maintain the Demolition Grab. This will result in maximum Demolition Grab reliability and productivity.

**Read this manual thoroughly** before attempting to operate, remove, disassemble, repair or troubleshoot the Demolition Grab or any of its components.

**Follow all the safety precautions** contained in this manual. **Failure to do so, can result in death, personal injury, injury to others, and property damage.**

## EXCAVATOR COMPATIBILITY

---

These excavator weight ranges are intended as a guideline only. Other factors, such as stick length, counterweights, undercarriage, etc., must be taken into consideration.



Mounting a Demolition Grab that is too heavy for the excavator can be dangerous and damage the machine. Verify excavator stability with the Demolition Grab before transport or operation.

Mounting a Demolition Grab that is too small for the excavator can damage the Demolition Grab and void Warranties. Please consult NPK Engineering for specific detailed information.

MODEL	RECOMMENDED EXCAVATOR CLASS	
	3rd member mounting	
	US ton	(Metric ton)
DG-4	3 - 4.5	(2.5 - 4)
DG-6	4.5 - 6.5	(4 - 6)
DG-9	5.5 - 10	(5 - 9)
DG-14	7.5 - 15.5	(7 - 14)
DG-16	11 - 17.5	(10 - 16)
DG-20/20A	15 - 22	(14 - 20)
DG-25	17.5 - 29	(16 - 26)
DG-30/30A	20 - 33	(18 - 30)
DG-40/40A	27.5 - 44	(25 - 40)
DG-50	38.5 - 55	(35 - 50)

## **SERIAL NUMBER LOCATION**

---

***DG-4, DG-6, DG-9, DG-14, DG-16, DG-20/20A,  
DG-25, DG-30/30A, DG-40/40A, DG-50***

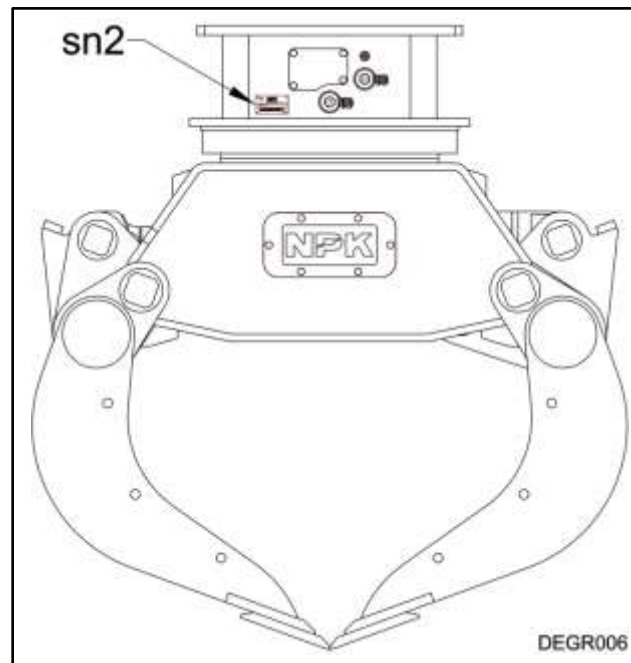

sn2 – serial number tag



# SPECIFICATIONS

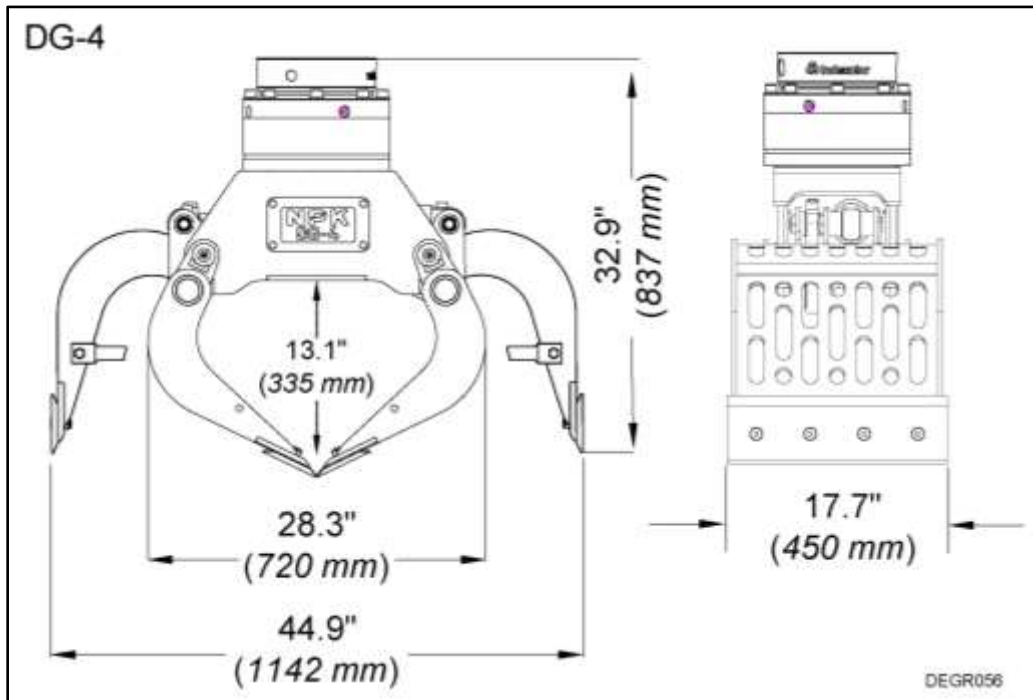

MODEL	WEIGHT		CLOSING FORCE		CAPACITY (volume)		MAXIMUM HOIST LOAD	
	lbs.	(kg)	tonf	(kN)	yd <sup>3</sup>	(liter)	lbs.	(kg)
DG-4	378	(172)	1.5	(15)	0.12	(90)	1,650	(750)

## ROTATION:

Rotation is 360°

## FLOW and PRESSURE SPECIFICATIONS:

MODEL	OIL FLOW MAIN JAWS		PRESSURE MAIN JAWS	
	gpm	(lpm)	psi	(bar)
DG-4	4 - 9	(15 - 35)	2,610 - 3,770	(180 - 260)

MODEL	OIL FLOW ROTATION		PRESSURE ROTATION	
	gpm	(lpm)	psi	(bar)
DG-4	3 - 6	(12 - 22)	1,500 - 2,000	(103 - 138)

**NOTE:** Specifications subject to change without notice.

# SPECIFICATIONS

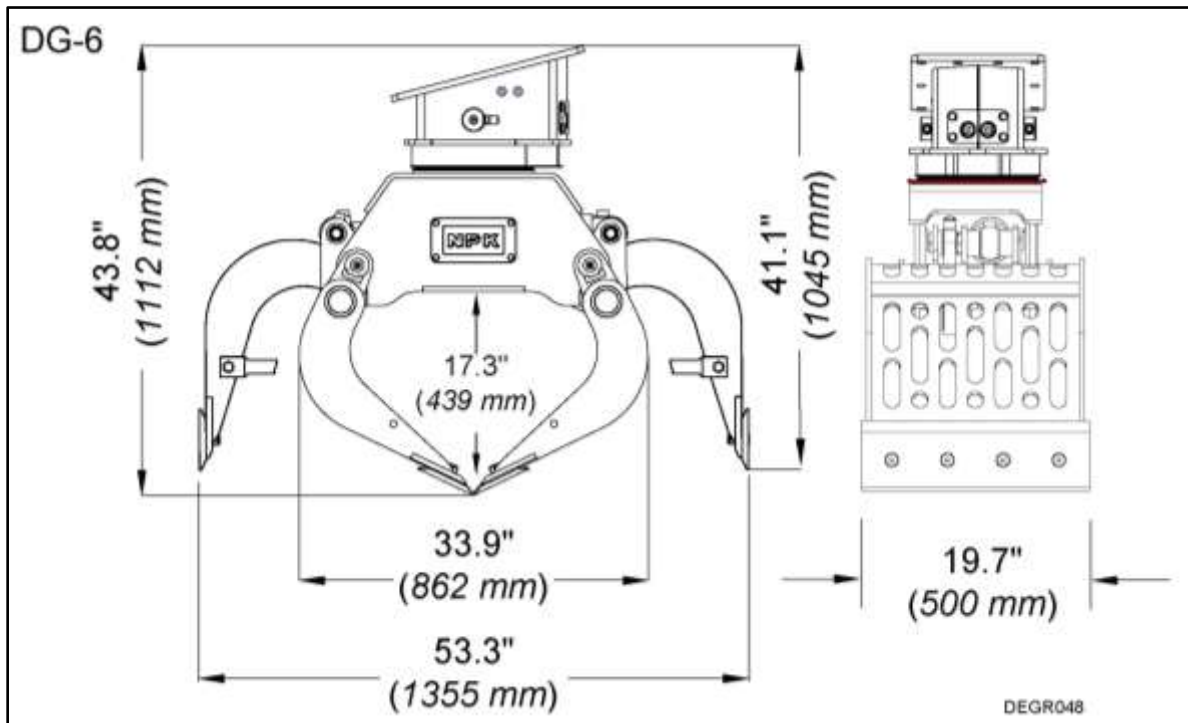

MODEL	WEIGHT		CLOSING FORCE		CAPACITY (volume)		MAXIMUM HOIST LOAD	
	lbs.	(kg)	tonf	(kN)	yd <sup>3</sup>	(liter)	lbs.	(kg)
DG-6	640	(290)	2.1	(21)	0.20	(150)	3,300	(1,500)

## ROTATION:

Rotation is 360°

## FLOW and PRESSURE SPECIFICATIONS:

MODEL	OIL FLOW MAIN JAWS		PRESSURE MAIN JAWS	
	gpm	(lpm)	psi	(bar)
DG-6	5 - 10	(20 - 40)	2,900 - 4,060	(200 - 280)

MODEL	OIL FLOW ROTATION		PRESSURE ROTATION	
	gpm	(lpm)	psi	(bar)
DG-6	2.5 - 4	(10 - 15)	1,450 - 1,885	(100 - 130)

**NOTE:** Specifications subject to change without notice.

# SPECIFICATIONS

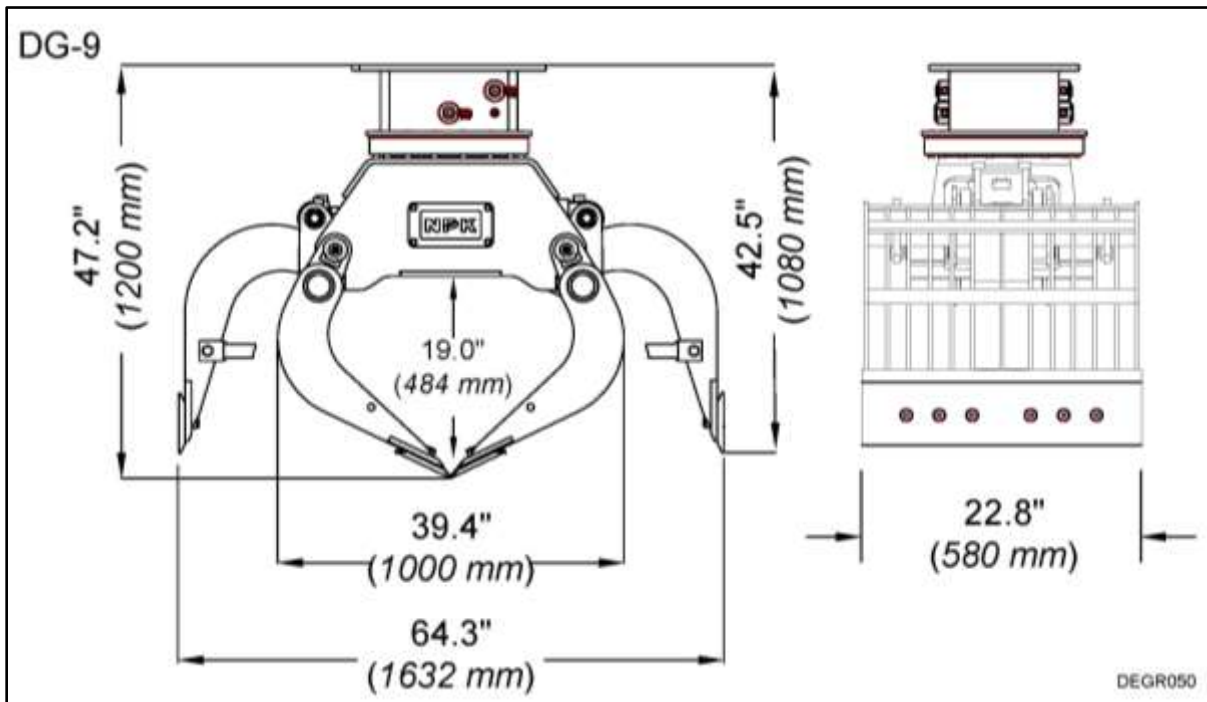

MODEL	WEIGHT		CLOSING FORCE		CAPACITY (volume)		MAXIMUM HOIST LOAD	
	lbs.	(kg)	tonf	(kN)	yd <sup>3</sup>	(liter)	lbs.	(kg)
DG-9	990	(450)	3.6	(32)	0.24	(180)	3,307	(1,500)

## ROTATION:

Rotation is 360°

## FLOW and PRESSURE SPECIFICATIONS:

MODEL	OIL FLOW MAIN JAWS		PRESSURE MAIN JAWS	
	gpm	(lpm)	psi	(bar)
DG-9	8 - 13	(30 - 50)	3,190 - 4,640	(220 - 320)

MODEL	OIL FLOW ROTATION		PRESSURE ROTATION	
	gpm	(lpm)	psi	(bar)
DG-9	3 - 4	(12 - 15)	1,450 - 1,885	(100 - 130)

**NOTE:** Specifications subject to change without notice.

# SPECIFICATIONS

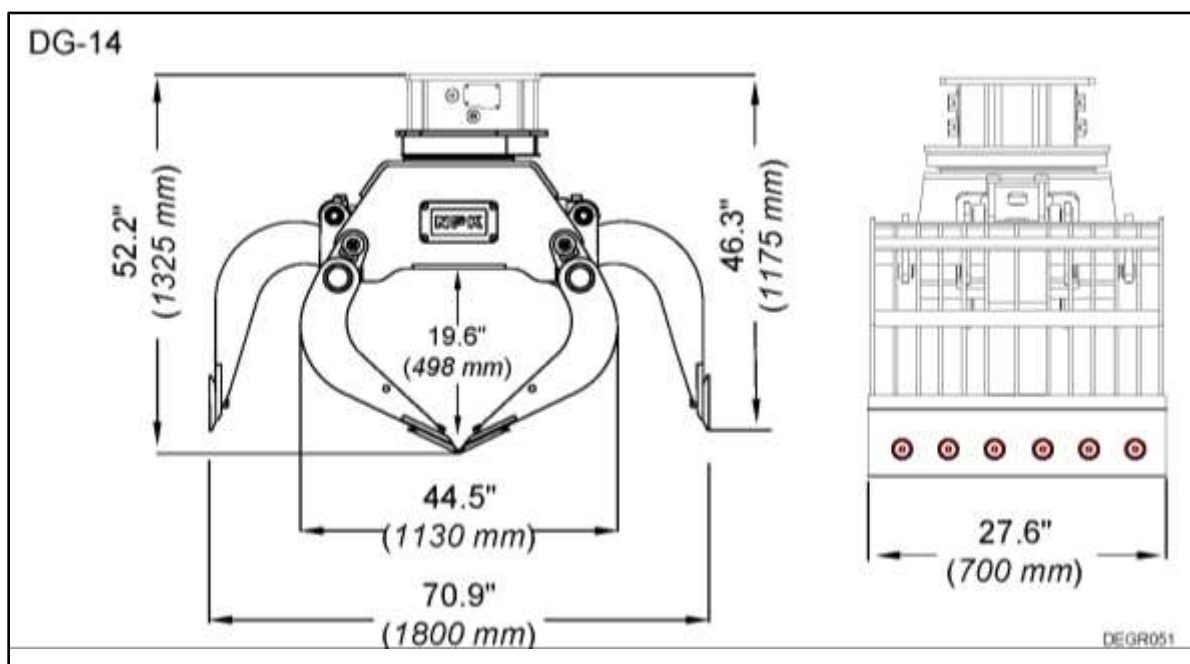

MODEL	WEIGHT		CLOSING FORCE		CAPACITY (volume)		MAXIMUM HOIST LOAD	
	lbs.	(kg)	tonf	(kN)	yd <sup>3</sup>	(liter)	lbs.	(kg)
DG-14	1,415	(642)	4.3	(38)	.39	(300)	6,614	(3,000)

## ROTATION:

Rotation is 360°

## FLOW and PRESSURE SPECIFICATIONS:

MODEL	OIL FLOW MAIN JAWS		PRESSURE MAIN JAWS	
	gpm	(lpm)	psi	(bar)
DG-14	8 - 16	(30 - 60)	3,625 - 5,075	(250 - 350)

MODEL	OIL FLOW ROTATION		PRESSURE ROTATION	
	gpm	(lpm)	psi	(bar)
DG-14	5 - 8	(20 - 30)	1,450 - 2,030	(100 - 140)

**NOTE: Specifications subject to change without notice.**

# SPECIFICATIONS

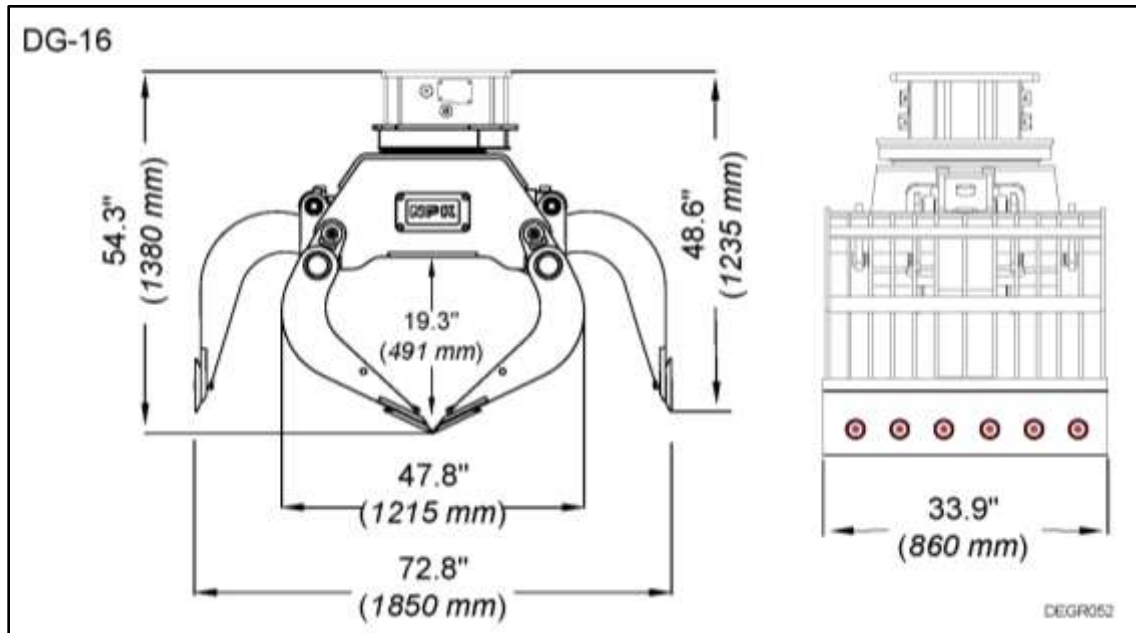

MODEL	WEIGHT		CLOSING FORCE		CAPACITY (volume)		MAXIMUM HOIST LOAD	
	lbs.	(kg)	tonf	(kN)	yd <sup>3</sup>	(liter)	lbs.	(kg)
DG-16	1,930	(875)	5.4	(48)	.56	(425)	7,716	(3,500)

## ROTATION:

Rotation is 360°

## FLOW and PRESSURE SPECIFICATIONS:

MODEL	OIL FLOW MAIN JAWS		PRESSURE MAIN JAWS	
	gpm	(lpm)	psi	(bar)
DG-16	16 - 26	(60 - 100)	3,625 - 5,075	(250 - 350)

MODEL	OIL FLOW ROTATION		PRESSURE ROTATION	
	gpm	(lpm)	psi	(bar)
DG-16	5 - 8	(20 - 30)	1,450 - 2,030	(100 - 140)

**NOTE:** Specifications subject to change without notice.

# SPECIFICATIONS

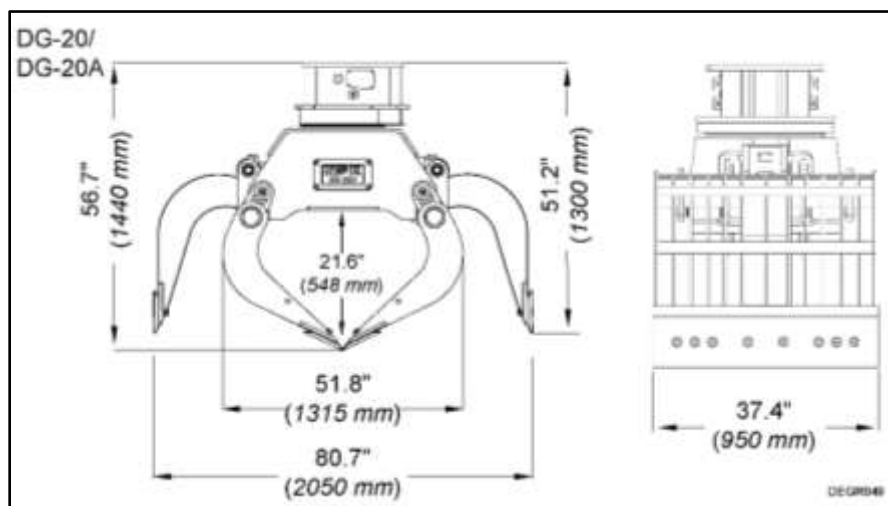

MODEL	WEIGHT		CLOSING FORCE		CAPACITY (volume)		MAXIMUM HOIST LOAD	
	lbs.	(kg)	tonf	(kN)	yd <sup>3</sup>	(liter)	lbs.	(kg)
DG-20/20A	2,756	(1,250)	6	(52)	.65	(500)	9,920	(4,500)

## ROTATION:

Rotation is 360°

## FLOW and PRESSURE SPECIFICATIONS:

MODEL	OIL FLOW MAIN JAWS		PRESSURE MAIN JAWS	
	gpm	(lpm)	psi	(bar)
DG-20/20A	16 - 26	(60 - 100)	3,625 - 5,075	(250 - 350)

MODEL	OIL FLOW ROTATION		PRESSURE ROTATION	
	gpm	(lpm)	psi	(bar)
DG-20/20A	8 - 13	(30 - 50)	1,450 - 2,030	(100 - 140)

## OPTIONAL SINGLE MOTOR

MODEL	OIL FLOW ROTATION		PRESSURE ROTATION	
	gpm	(lpm)	psi	(bar)
DG-20/20A	5 - 8	(20 - 30)	1,450 - 2,030	(100 - 140)

**NOTE:** Specifications subject to change without notice.

# SPECIFICATIONS

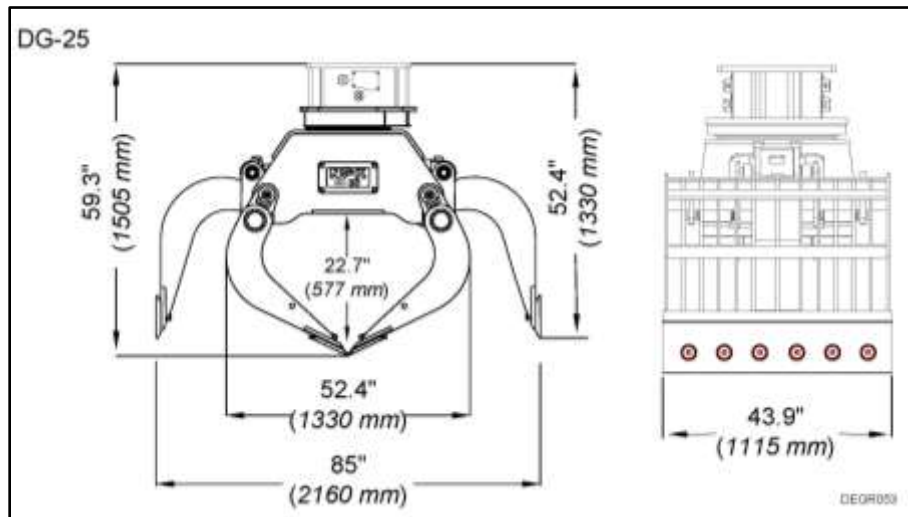

MODEL	WEIGHT		CLOSING FORCE		CAPACITY (volume)		MAXIMUM HOIST LOAD	
	lbs.	(kg)	tonf	(kN)	yd <sup>3</sup>	(liter)	lbs.	(kg)
DG-25	3,216	(1,450)	6	(60)	.78	(600)	9,920	(4,500)

## ROTATION:

Rotation is 360°

## FLOW and PRESSURE SPECIFICATIONS:

MODEL	OIL FLOW MAIN JAWS		PRESSURE MAIN JAWS	
	gpm	(lpm)	psi	(bar)
DG-25	16 - 26	(60 - 100)	3,625 - 5,075	(250 - 350)

MODEL	OIL FLOW ROTATION		PRESSURE ROTATION	
	gpm	(lpm)	psi	(bar)
DG-25	8 - 13	(30 - 50)	1,450 - 2,030	(100 - 140)

## OPTIONAL SINGLE MOTOR

MODEL	OIL FLOW ROTATION		PRESSURE ROTATION	
	gpm	(lpm)	psi	(bar)
DG-25	5 - 8	(20 - 30)	1,450 - 2,030	(100 - 140)

**NOTE: Specifications subject to change without notice.**

# SPECIFICATIONS

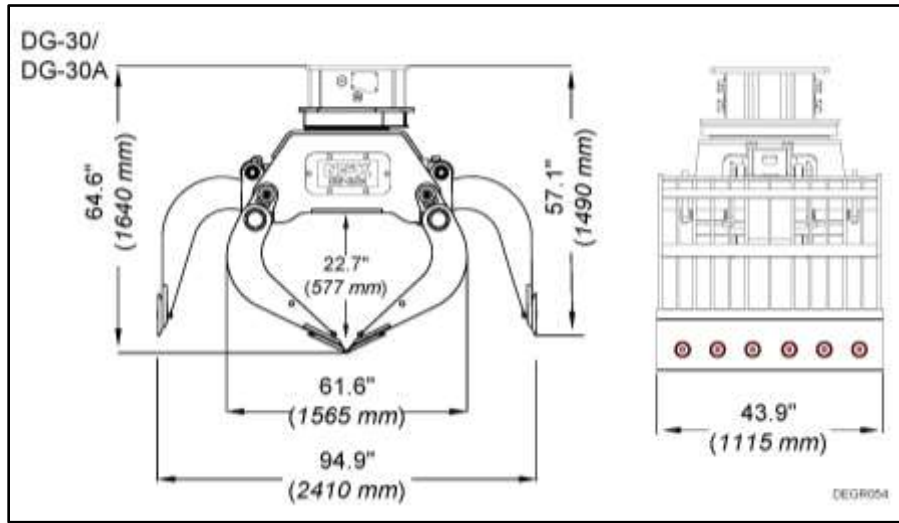

MODEL	WEIGHT		CLOSING FORCE		CAPACITY (volume)		MAXIMUM HOIST LOAD	
	lbs.	(kg)	tonf	(kN)	yd <sup>3</sup>	(liter)	lbs.	(kg)
DG-30/30A	4,078	(1,850)	8.1	(72)	1.05	(800)	12,125	(5,500)

## ROTATION:

Rotation is 360°

## FLOW and PRESSURE SPECIFICATIONS:

MODEL	OIL FLOW MAIN JAWS		PRESSURE MAIN JAWS	
	gpm	(lpm)	psi	(bar)
DG-30/30A	21 - 32	(80 - 120)	3,625 - 5,075	(250 - 350)

MODEL	OIL FLOW ROTATION		PRESSURE ROTATION	
	gpm	(lpm)	psi	(bar)
DG-30/30A	8 - 13	(30 - 50)	1,450 - 2,030	(100 - 140)

## OPTIONAL SINGLE MOTOR

MODEL	OIL FLOW ROTATION		PRESSURE ROTATION	
	gpm	(lpm)	psi	(bar)
DG-30/30A	5 - 8	(20 - 30)	1,450 - 2,030	(100 - 140)

**NOTE: Specifications subject to change without notice.**



# SPECIFICATIONS

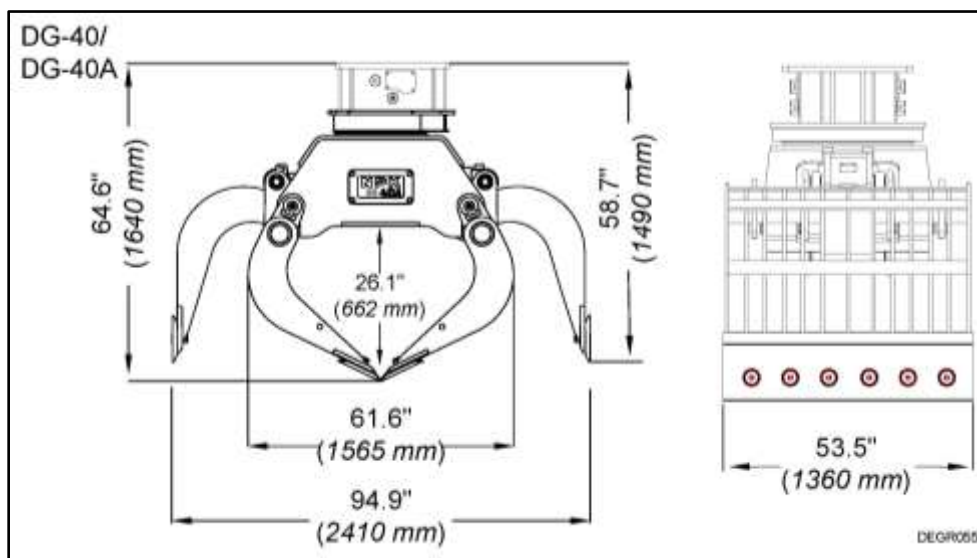

MODEL	WEIGHT		CLOSING FORCE		CAPACITY (volume)		MAXIMUM HOIST LOAD	
	lbs.	(kg)	tonf	(kN)	yd <sup>3</sup>	(liter)	lbs.	(kg)
DG-40/40A	4,519	(2,050)	8.1	(72)	1.18	(900)	12,125	(5,500)

## ROTATION:

Rotation is 360°

## FLOW and PRESSURE SPECIFICATIONS:

MODEL	OIL FLOW MAIN JAWS		PRESSURE MAIN JAWS	
	gpm	(lpm)	psi	(bar)
DG-40/40A	21 - 32	(80 - 120)	3,625 - 5,075	(250 - 350)

MODEL	OIL FLOW ROTATION		PRESSURE ROTATION	
	gpm	(lpm)	psi	(bar)
DG-40/40A	8 - 13	(30 - 50)	1,450 - 2,030	(100 - 140)

## OPTIONAL SINGLE MOTOR

MODEL	OIL FLOW ROTATION		PRESSURE ROTATION	
	gpm	(lpm)	psi	(bar)
DG-40/40A	5 - 8	(20 - 30)	1,450 - 2,030	(100 - 140)

**NOTE: Specifications subject to change without notice.**

# SPECIFICATIONS

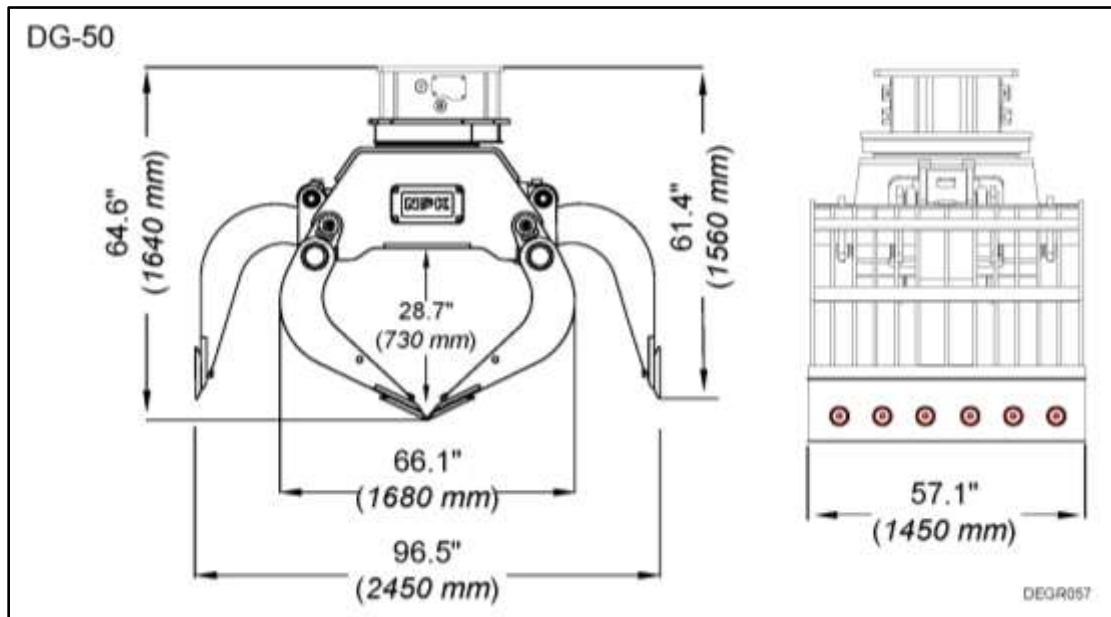

MODEL	WEIGHT		CLOSING FORCE		CAPACITY (volume)		MAXIMUM HOIST LOAD	
	lbs.	(kg)	tonf	(kN)	yd <sup>3</sup>	(liter)	lbs.	(kg)
DG-50	5,512	(2,500)	10.1	(90)	1.44	(1100)	12,125	(5,500)

## ROTATION:

Rotation is 360°

## FLOW and PRESSURE SPECIFICATIONS:

MODEL	OIL FLOW MAIN JAWS		PRESSURE MAIN JAWS	
	gpm	(lpm)	psi	(bar)
DG-50	26 - 37	(100 - 140)	3,625 - 5,075	(250 - 350)

MODEL	OIL FLOW ROTATION		PRESSURE ROTATION	
	gpm	(lpm)	psi	(bar)
DG-50	8 - 13	(30 - 50)	1,450 - 2,320	(100 - 160)

**NOTE: Specifications subject to change without notice.**

# HYDRAULIC INSTALLATION

---

## HYDRAULIC LINES

Typically, the pressure line to close is arranged on the left side of the boom and the open line is on the right side.

## SHUT-OFF VALVES

Some hydraulic installation kits use two shut-off valves (k4) on the dipper stick (k1) of the carrier. These valves control the hydraulic oil going to the close side (m3) and the open side (m4) from the Demolition Grab attachment.

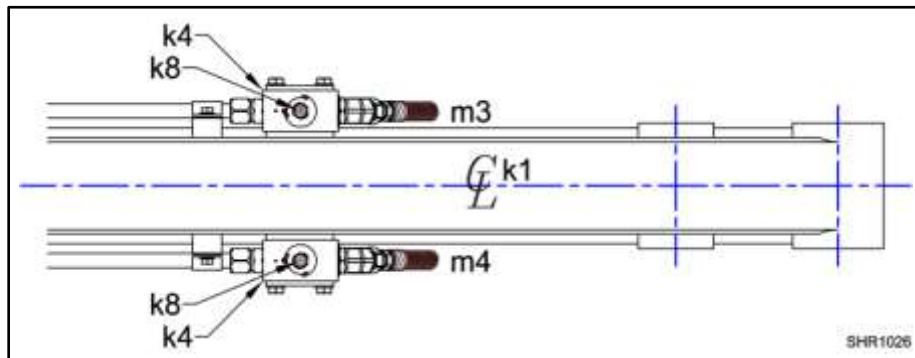

Pressure test ports (k8) are in the shut-off valves (k4). Each shut-off valve has an “ON” (k5) and an “OFF” (k6) position.

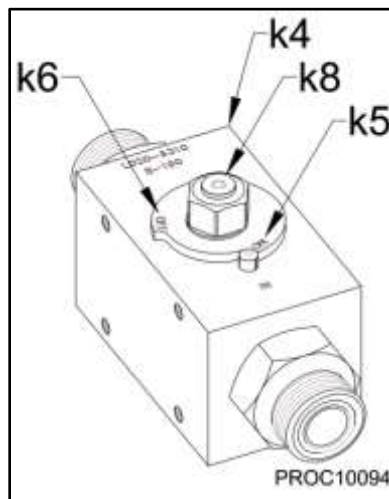

# HYDRAULIC INSTALLATION

## PORT CONNECTION DIAGRAM

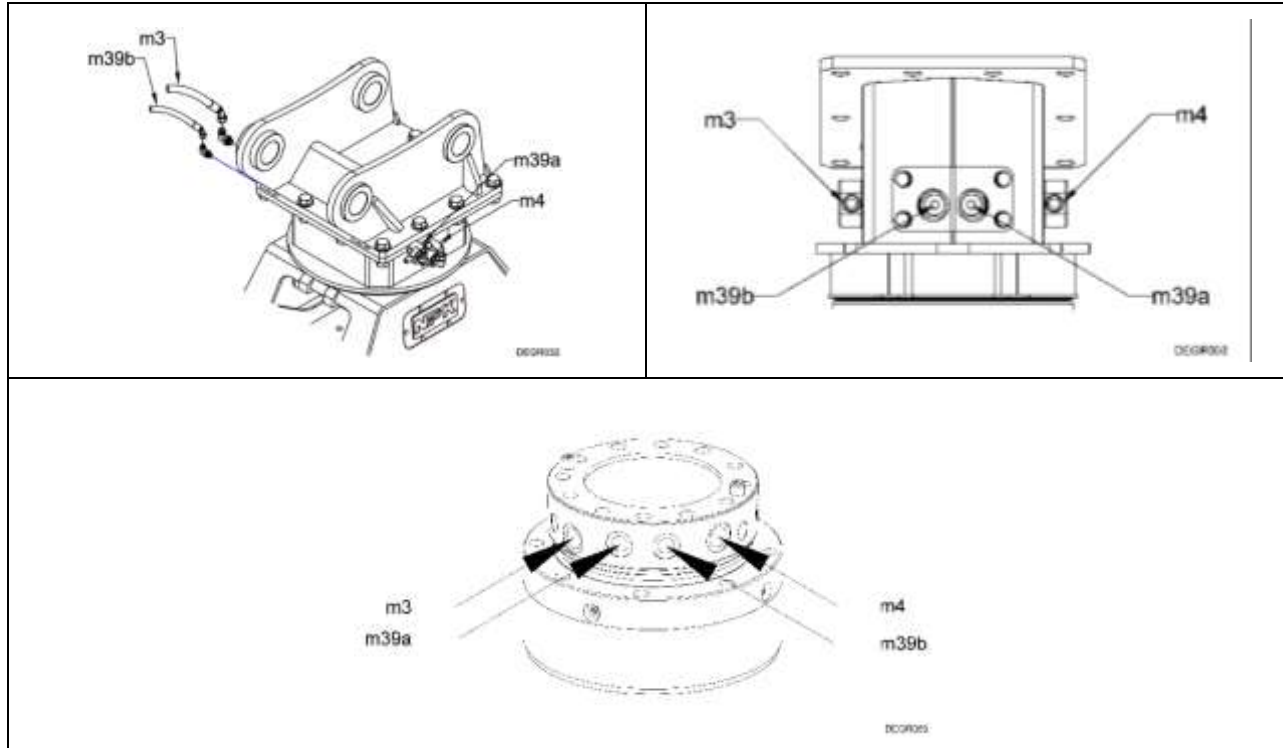

<b>m3</b>	HOSE: arm close
<b>m4</b>	HOSE: arm open
<b>m39a</b>	ROTATION HOSE: for clockwise movement
<b>m39b</b>	ROTATION HOSE: for counterclockwise movement

MODEL	OPEN/CLOSE	ROTATION
<b>DG-4</b>	8 JIC	8 JIC
<b>DG-6</b>	8 JIC	8 JIC
<b>DG-9</b>	8 JIC	8 JIC
<b>DG-14</b>	8 JIC	8 JIC
<b>DG-16</b>	12 JIC	8 JIC
<b>DG-20/20A</b>	12 JIC	8 JIC
<b>DG-25</b>	12 JIC	8 JIC
<b>DG-30/30A</b>	12 JIC	8 JIC
<b>DG-40/40A</b>	12 JIC	8 JIC
<b>DG-50</b>	12 JIC	8 JIC

# DEMOLITION GRAB HYDRAULIC CIRCUITS

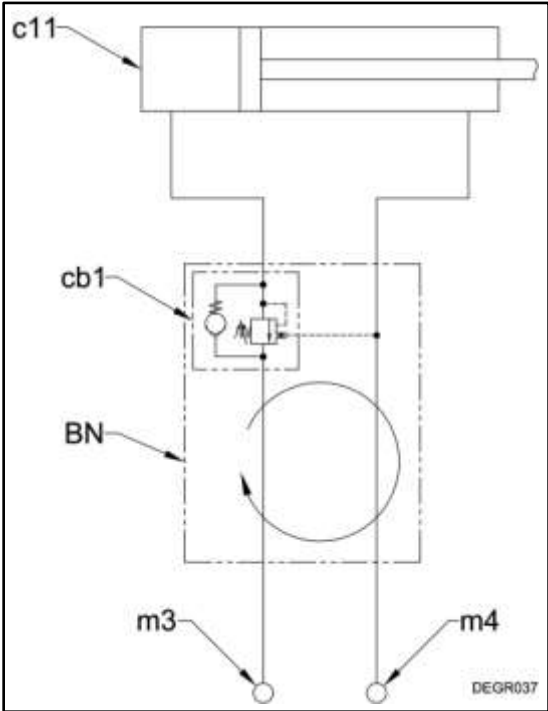

**CYLINDER HYDRAULIC CIRCUIT**

<b>BN</b>	ROTARY JOINT ASSEMBLY
<b>c11</b>	CYLINDER
<b>cb1</b>	COUNTERBALANCE VALVE
<b>m3</b>	ARM CLOSE PORT
<b>m4</b>	ARM OPEN PORT

# DEMOLITION GRAB HYDRAULIC CIRCUITS

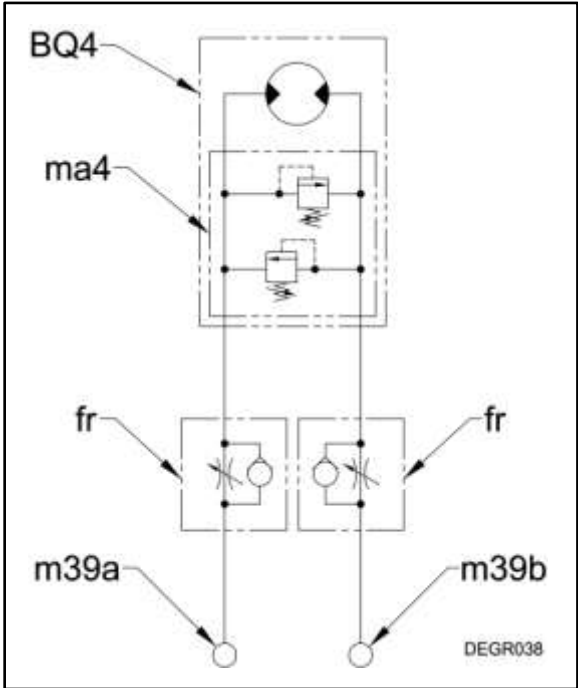

## SINGLE MOTOR HYDRAULIC CIRCUIT

<b>BQ4</b>	HYDRAULIC MOTOR
<b>fr</b>	FLOW REGULATOR
<b>ma4</b>	CROSS PORT RELIEF
<b>m39a</b>	CLOCKWISE ROTATION PORT
<b>m39b</b>	COUNTER-CLOCKWISE ROTATION PORT

# DEMOLITION GRAB HYDRAULIC CIRCUITS

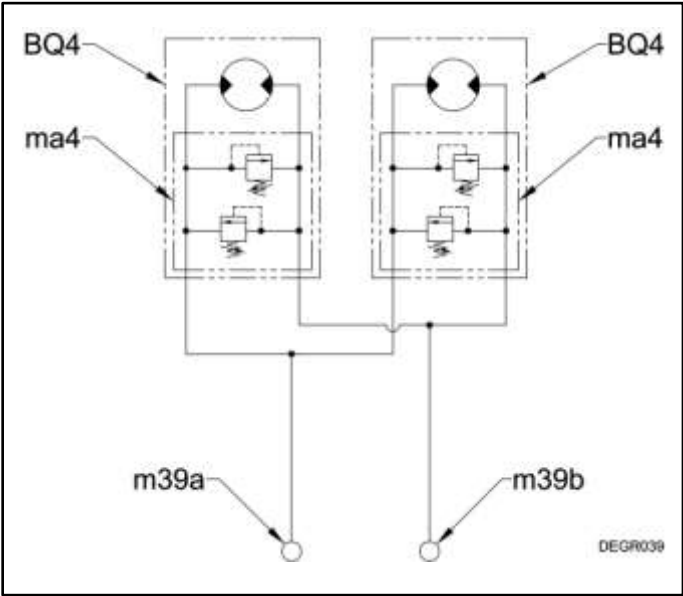

**DUAL MOTOR HYDRAULIC CIRCUIT**

<b>BQ4</b>	HYDRAULIC MOTOR
<b>ma4</b>	CROSS PORT RELIEF
<b>m39a</b>	CLOCKWISE ROTATION PORT
<b>m39b</b>	COUNTER-CLOCKWISE ROTATION PORT

# MOUNTING INSTALLATION

NPK Mounting Installation Kits include the parts required to adapt the NPK Demolition Grab to the stick or arm of the excavator. The kits include all necessary stick and link pins, bolts, etc.

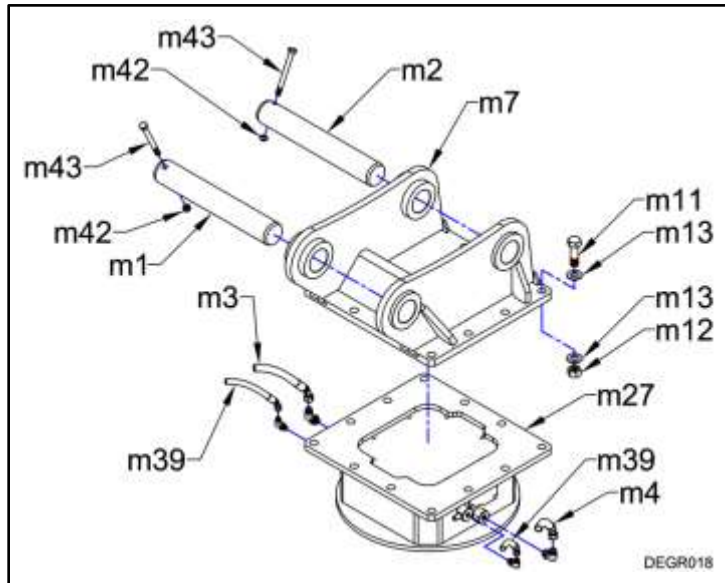

<b>m1</b>	STICK PIN (optional)
<b>m2</b>	LINK PIN (optional)
<b>m3</b>	WHIP HOSE - CLOSE (optional)
<b>m4</b>	WHIP HOSE - OPEN (optional)
<b>m7</b>	TOP BRACKET
<b>m11</b>	BRACKET BOLT
<b>m12</b>	HEX NUT
<b>m13</b>	WASHER
<b>m27</b>	SWIVEL TOP
<b>m39</b>	ROTATION HOSE (optional)
<b>m42</b>	HEX NUT
<b>m43</b>	PIN BOLT



# MOUNTING INSTALLATION

---

## MOUNTING TO THE EXCAVATOR

1. Position the Demolition Grab on wood blocks (t20) as shown.
2. Align the stick pin bore (m24). Install the stick pin (m1).
3. Align the link pin bore (m25). Install the link pin (m2).
4. Clean away any dirt found on the hose connections, connect the whip hoses (m3 and m4) and the rotation hoses (m39).
5. Open the shut off valves (k4).
6. Remove safety bar.

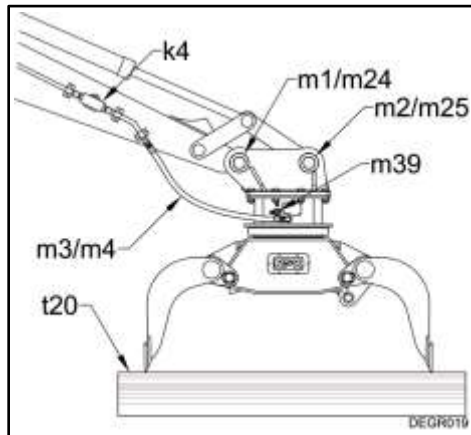

### ATTENTION

The hydraulic lines must be handled carefully to prevent contamination from entering the Demolition Grab or the carrier hydraulic system.

## REMOVAL FROM THE CARRIER

1. Retract the cylinder to open jaws fully.
2. Position the Demolition Grab horizontal on wood blocks (t20), as shown above.
3. Install safety bar.
4. Close the shut-off valves.
5. Shut off engine and relieve all hydraulic pressure.
6. Disconnect the hydraulic hoses before setting the Demolition Grab down. Install plugs in the hydraulic hoses and caps on the stick tubes to keep out contamination.

## STORAGE OF DEMOLITION GRAB

---

1. Make sure the hydraulic hoses are plugged and stick tubes capped.
2. Grease all lubrication points, see page 32.
3. If stored outdoors, cover with waterproof tarp.

# OPERATING INSTRUCTIONS

Before operating the NPK Demolition Grab, be sure to read the safety information and perform the daily and weekly maintenance as specified in this manual.



**DO NOT OPERATE THE DEMOLITION GRAB WITHOUT DEMOLITION GUARDS IN PLACE!**

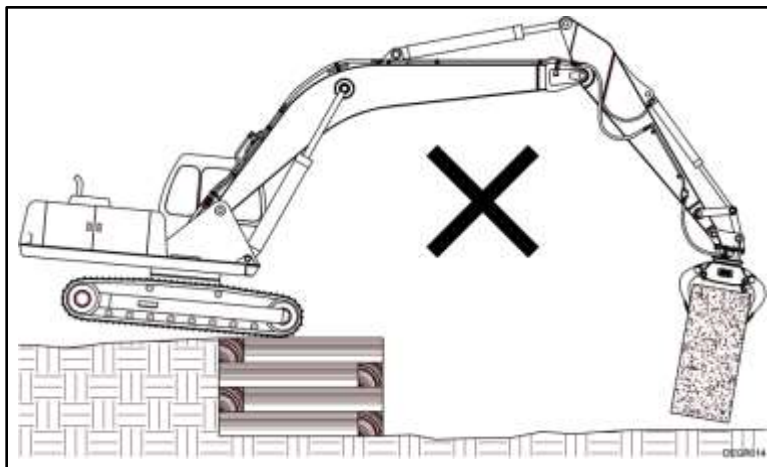

**DO NOT LIFT OR LOAD BEYOND THE CAPACITY OF THE DEMOLITION GRAB OR THE EXCAVATOR.**

# OPERATING INSTRUCTIONS

USE THE DEMOLITION GRAB ONLY FOR THE APPLICATION FOR WHICH IT IS INTENDED:

- The NPK Demolition Grab is an attachment which is designed for grabbing and moving of materials which are on a solid base, under water or in a construction setting, but in such a way, that no danger is caused to the surroundings and operators.

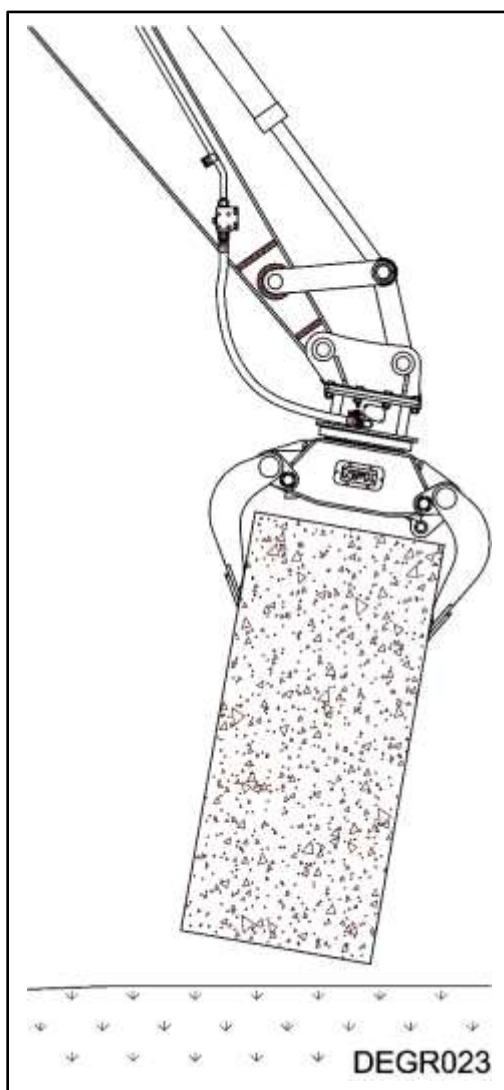

# OPERATING INSTRUCTIONS

## ATTENTION OPERATING TECHNIQUES AND PRECAUTIONS

**Do not** use the Demolition Grab with the excavator cylinders fully extended (96) or retracted (97).

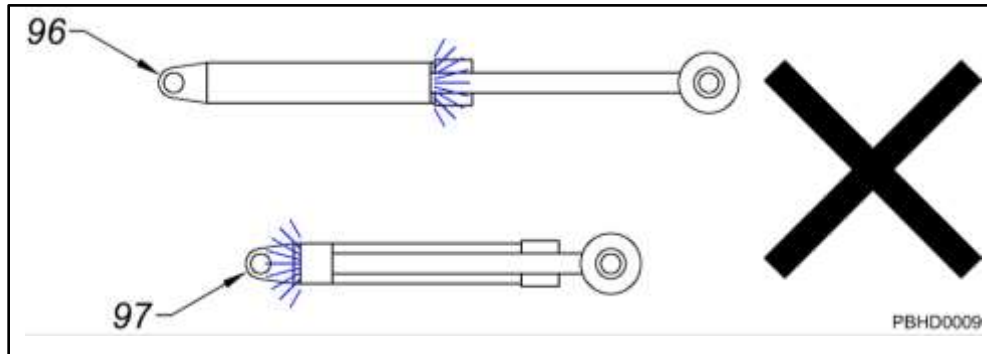

**Do not** strike the material with the Demolition Grab jaw set (DO1). **Do not** push, pull or scrape material with the Demolition Grab.

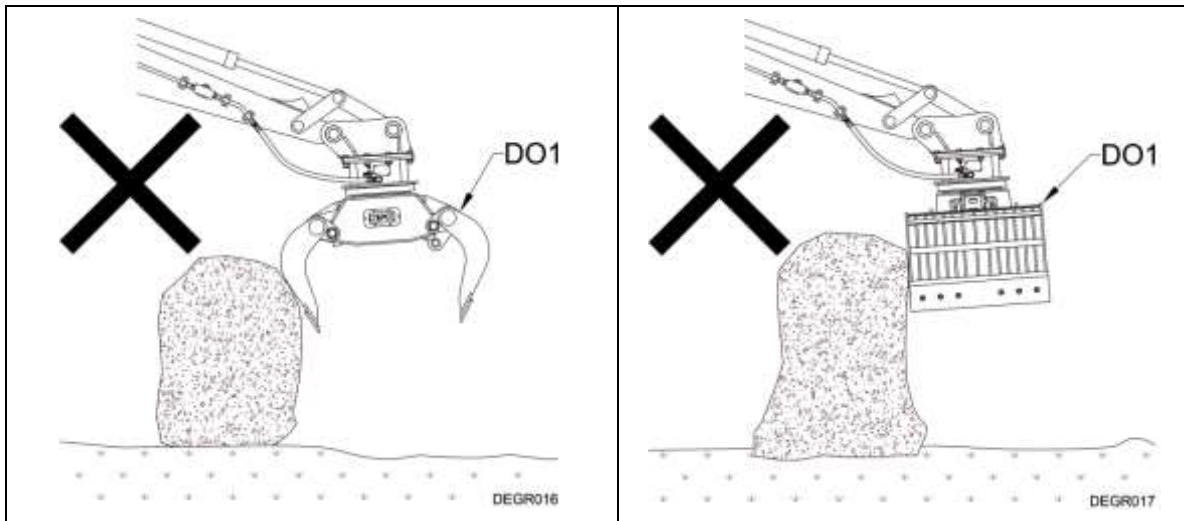

# OPERATING INSTRUCTIONS

## ATTENTION

## OPERATING TECHNIQUES AND PRECAUTIONS

**Do not pry, twist or pull with the excavator.**

The excavator is used as a way of positioning the Demolition Grab and supplying hydraulic power to the Demolition Grab.

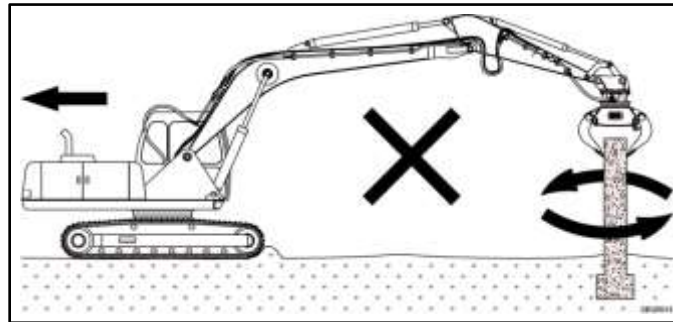

**Do not** operate the Demolition Grab on an excavator with a combination Hydraulic Hammer/Crusher hydraulic installation kit without first isolating line-mounted accumulators (k23).

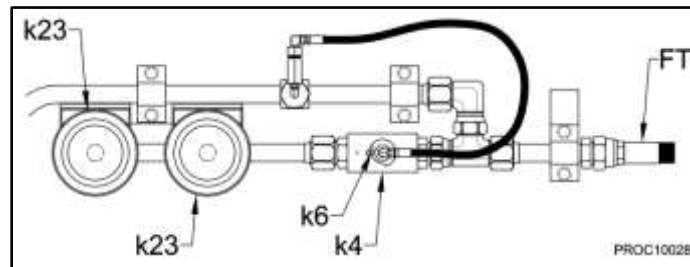

1. Shut-off valve (k4) must be in the off (k6) position for use with the Demolition Grab.
2. Return line from hammer/compactor (Demolition Grab open) (FT).

On some later NPK hydraulic kits, the lockout feature is done automatically using an accumulator isolation valve (k26). Consult with NPK at (440) 232-7900 if you are unsure of what your machine is equipped with.

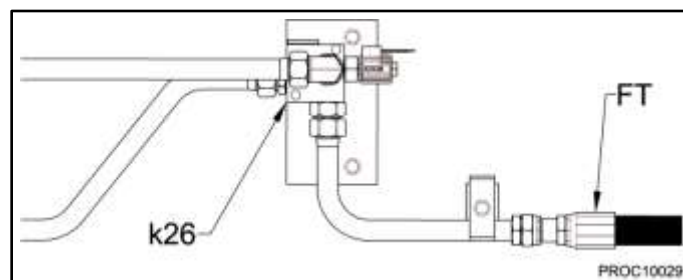

# OPERATING INSTRUCTIONS

---

For most efficient operation, open the jaw only wide enough to grasp the material. Grasp the material to be grabbed as deep into the throat of the Demolition Grab as possible. Do not force the material into the jaws.

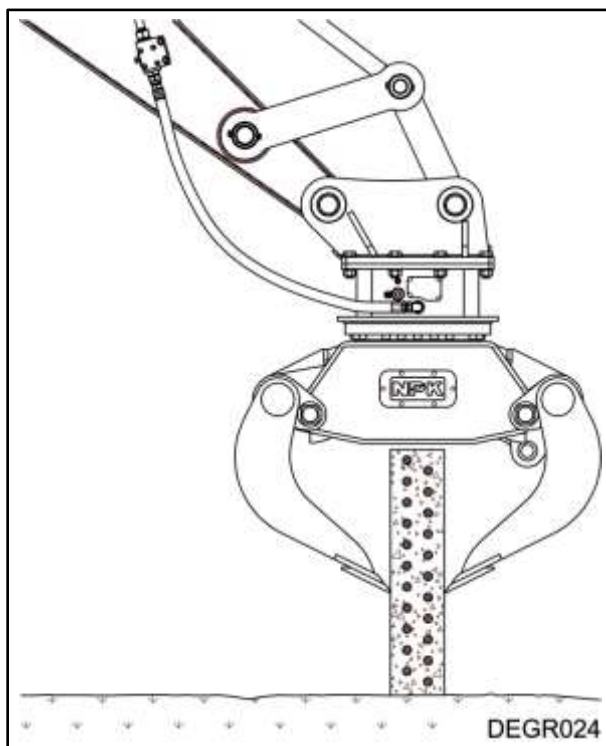

If you have any questions on operating the Demolition Grab, please contact your local NPK dealer or call the NPK Service Department at (440) 232-7900.

# GENERAL MAINTENANCE

---

***REFER TO IMPORTANT SAFETY INFORMATION SECTION***

## DAILY INSPECTION AND MAINTENANCE

The functions that the Demolition Grab performs are demanding jobs in tough environments. Therefore, it is extremely important that the following maintenance and inspection procedures be performed daily.

- ***Grease all lubrication points!*** Use moly EP2 or equivalent grease. Lubrication points are at the following locations as shown on page 32.
- Check for oil leaks at the Cylinder Piston Rod and all of the Demolition Grab's hoses and fittings.
- Check all fasteners for looseness. Retighten if necessary.
- Inspect all welds and repair as necessary.
- Inspect the hydraulic hoses for wear, damage, or oil leakage.

# GENERAL MAINTENANCE

## ARM MAINTENANCE

Check for wear of the replaceable cutters (dg3 and dg4). If the cutters no longer touch, they must be replaced. The diagram below shows new (CY) and worn (CZ) cutters.

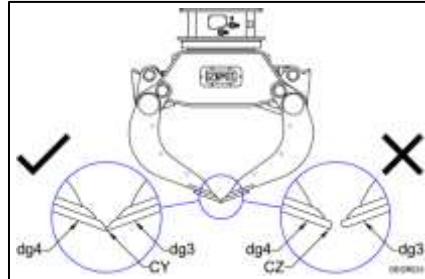

## FRAME MAINTENANCE

Inspect frame welds for cracks or other deformities.

## FRAME CRACK REPAIR

1. Drill  $3/16$ " ( $5\text{ mm}$ ) hole through the plate at the end of the crack to prevent further crack propagation.
2. Grind out the crack and weld as shown. Use AWS E7018 or equivalent welding rod.
- 3a. For plate sizes up to  $3/4$ " ( $20\text{ mm}$ ) thick, use the weld joint shown below:

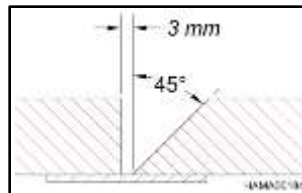

- 3b. For plate sizes over  $3/4$ " ( $20\text{ mm}$ ) thick, use weld joint shown below:

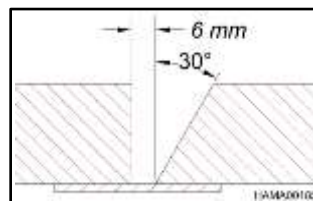

4. Grind weld flush as shown:

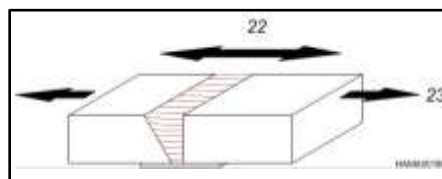

22 – Direction of Grinding  
23 – Direction of Principle Stress



# GENERAL MAINTENANCE

---

## LUBRICATION POINTS

- GR1** Cylinder rod pin: one lubrication point located at drive arm attachment end. 10 strokes from grease gun every 4 hours.
- GR3** Jaw pivot pin: one lubrication point for each pin, located on main frame. 15 strokes from grease gun per fitting every 4 hours.
- GR4** Slewing ring/pinion teeth: three lubrication points on outside diameter of the slewing ring. 5 strokes from grease gun per fitting once per shift.
- GR5** Motor pinion: one lubrication point. 5 strokes from grease gun once per shift.
- GR6** Cylinder base end pin: one lubrication point located at arm attachment end. 10 strokes from grease gun every 4 hours.
- GR9** Link plate pivot pins: one lubrication point each end per link. 10 strokes from grease gun every 4 hours.

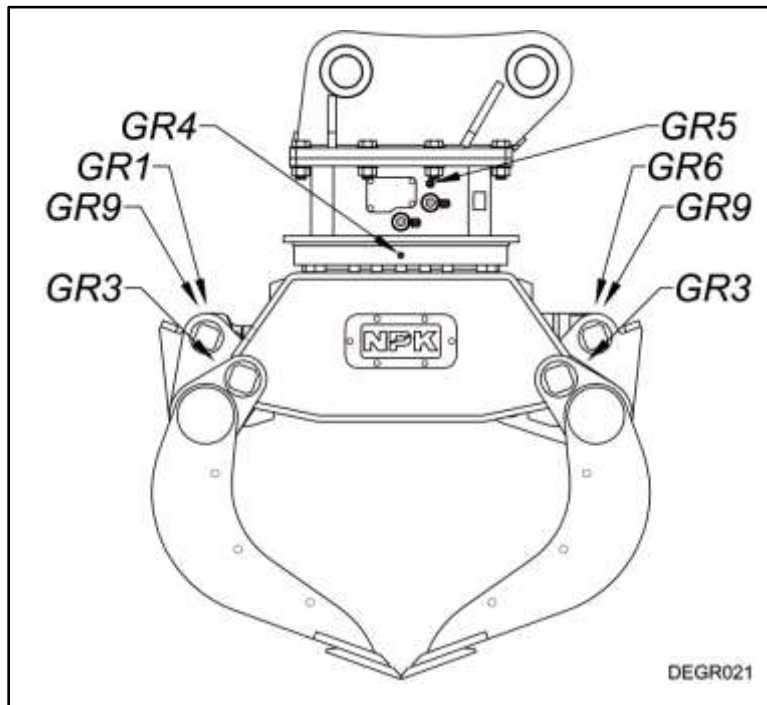

# SLEWING RING INSPECTION AND MAINTENANCE

## MEASURING MAXIMUM AXIAL MOVEMENT

1. While the unit is attached to the excavator, position the Demolition Grab in the vertical position.
2. Using a dial indicator (t40), lock the base of the dial indicator onto the lower frame of the Demolition Grab. Indicate the other end of the dial onto the top bracket face as shown. Using the excavator, slightly rock the Demolition Grab back and forth using slight stick movement. Note the movement shown by the dial. Take this reading (d59) in four places. If your readings are greater than shown, please contact the NPK Service Department at (440) 232-7900.

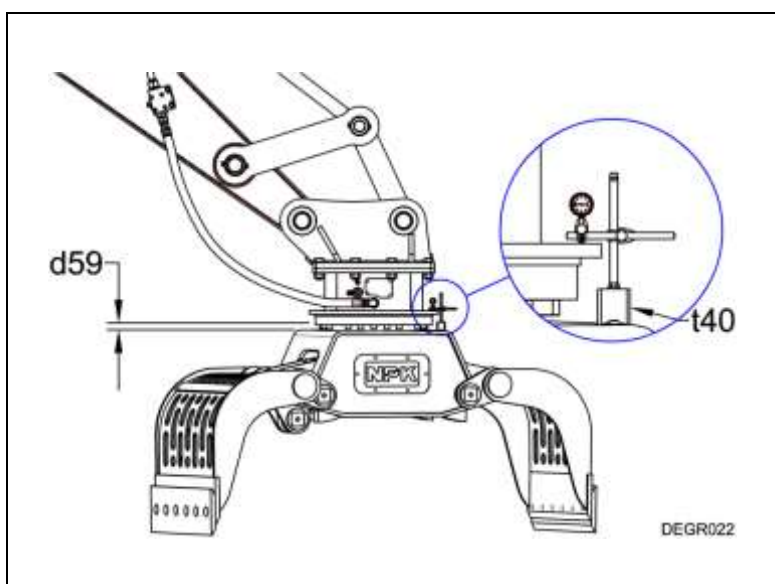

MODEL	NEW MAXIMUM inch (mm)
ALL	<.010 (0.25)
MODEL	MAXIMUM ALLOWABLE WEAR inch (mm)
ALL	0.138 (3.50)

# NPK ASSEMBLY LUBRICANT

---

**NPK ASSEMBLY LUBRICANT** is specially formulated to provide quick, positive lubrication. Oil rich ingredients, plus a free-flowing light lithium grease, offer top lubrication, as well as long lasting protection against rust and corrosion. **NPK ASSEMBLY LUBRICANT** even “creeps” into remote, normally inaccessible areas to lubricate and safeguard interior metal surfaces. **NPK ASSEMBLY LUBRICANT** is ideal for use on all metal-to-metal surfaces.

## **DIRECTIONS FOR USE**

1. Wipe off exposed surfaces.
2. Shake vigorously to thoroughly mix contents.
3. Spray liberally on areas requiring lubrication.

**NPK ASSEMBLY LUBRICANT** contains NPK-10 Metal Treatment and is ideal for use in the assembly of all NPK products. **NPK ASSEMBLY LUBRICANT** comes in a 16-ounce bottle with sprayer and can be ordered using part number H010-5010.



# ROTARY JOINT MAINTENANCE

## HYDRAULIC ROTARY JOINT ASSEMBLY

The hydraulic rotary joint assembly (BN) is mounted inside the swivel top assembly (m27) which is under the top bracket (m7) that pins to the carrier and is bolted to the slewing ring (BT) which rotates the Demolition Grab's main frame. Hydraulic oil for both open and close operations passes through it. The rotary joint assembly consists of two main parts, the "Spindle Case", which contains the oil seals and the "Spindle", which rotates the Demolition Grab's main frame.

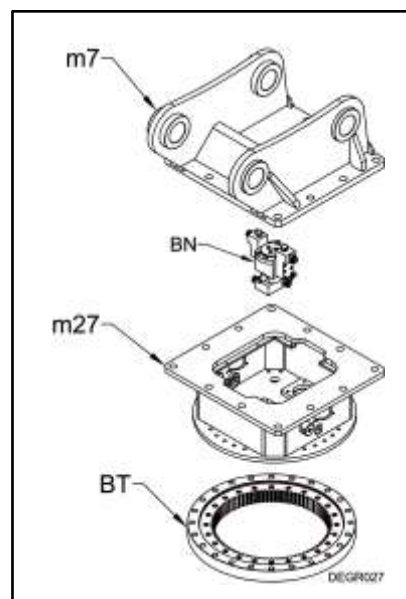

## LEAKAGE OF THE SEALS

External leakage or internal (*bypassing*) of hydraulic oil will require the replacement of the seals in the rotary joint assembly. For external leakage, please review the seal replacement procedure in the next section. If internal leakage is suspected, please proceed to the "**TESTING THE ROTARY JOINT SEALS FOR INTERNAL LEAKAGE**" section.

## TESTING THE ROTARY JOINT SEALS FOR INTERNAL LEAKAGE

If internal seal leakage is suspected, before disassembling the rotary joint assembly (BN), the counterbalance valve cartridge (cb1) pressure setting should be checked. Internal leakage will most likely prevent the unit from reaching relief pressure in the close function. The relief cartridge is located below the rotary joint in a block that the hose connections to the cylinder are located. Access to the relief valve cartridge is through the cover plates of the swivel top assembly.

**NOTE:** *Before attempting to adjust the relief setting, please check that the relief valve cartridge has not loosened in the block.*

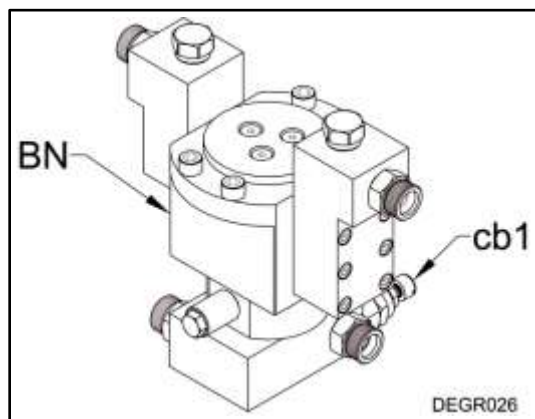

# ROTARY JOINT MAINTENANCE

## TESTING THE ROTARY JOINT SEALS FOR INTERNAL LEAKAGE

### PROCEDURE

Install a 0 – 5,000 psi gauge (g8f) in the NPK shut-off (k4) located on the stick of the carrier. Close the arms and keep the function activated and read the pressure. Compare the pressure reached with the specifications for your model Demolition Grab (GZ). If the proper relief pressure cannot be reached, you must disassemble the rotary joint to check for failed seals.

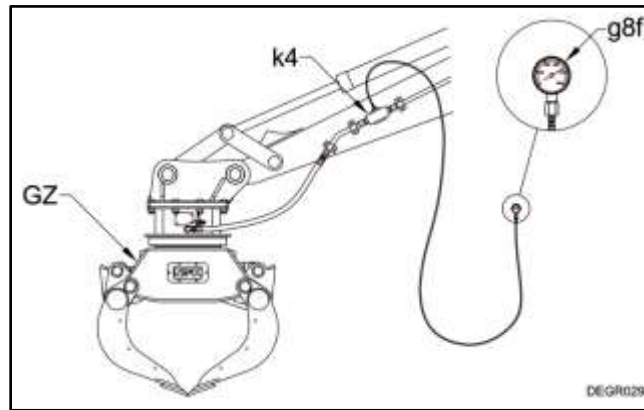

## REPLACEMENT OF THE SEALS IN THE ROTARY JOINT



*The arms (dg1 and dg2) of the Demolition Grab should be opened and safety bar (t79) installed during repair. Close the NPK shut-off valves on the stick of the carrier.*

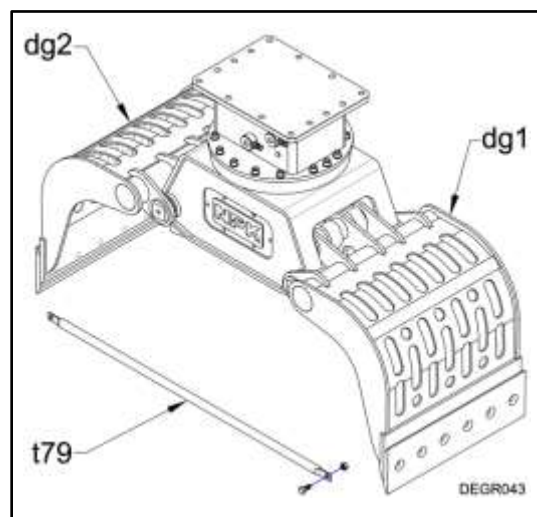

# ROTARY JOINT MAINTENANCE

## REPLACEMENT OF THE SEALS IN THE ROTARY JOINT

### Step 1

Remove the top bracket from the swivel flat top assembly. Remove the joint fitting adapter fittings (m44) from the spindle case manifold blocks. Remove the hoses (AO) from the spindle base manifold. Remove the bolt (AF) and spacer (ZZ) from the spindle base manifold. Remove the four mounting bolts (AF1) from the spindle case. Pull the rotary joint assembly (BN) from the swivel flat top assembly.

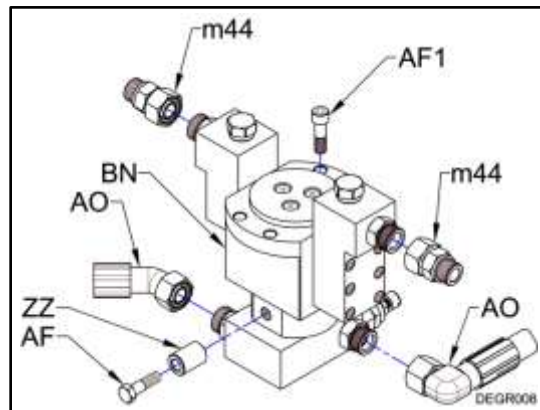

Figure 1

### Step 2

Remove the three flat head socket screws (AF9). Remove the top plate (CH) and o-ring (RR) from the spindle case (BZ). Remove the spindle case and o-ring from the spindle (CA).

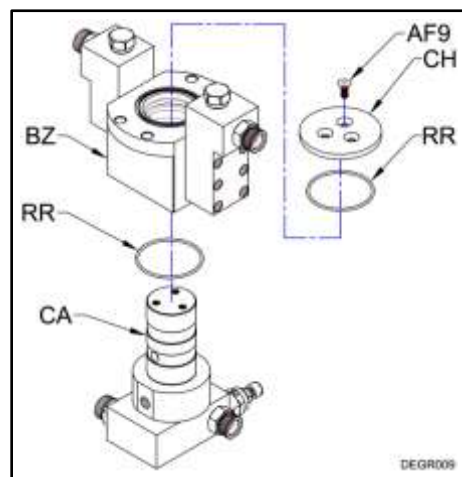

Figure 2

# ROTARY JOINT MAINTENANCE

## REPLACEMENT OF THE SEALS IN THE ROTARY JOINT

### Step 3

#### *Inspection:*

Visually inspect the sealing surfaces of the spindle (CA) for damage, which may hamper the ability of the main seals to seal. Polishing the surfaces (120) may clean up light scratching. Heavy scratching or galling may indicate rotator bearing play.

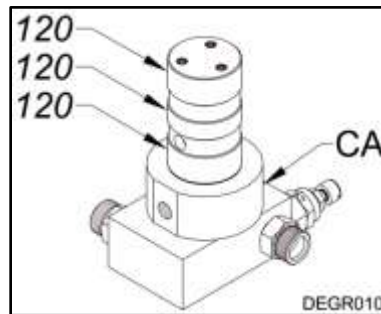

Figure 3

### Step 4

#### *Seal removal and replacement:*

Sealing is accomplished by the use of main seals, which ride against the “Spindle” and glide bearings. Remove the main seals and glide rings with a seal pick (note the proper placement of main seals and glide bearings). Check the grooves (118) in the “Spindle Case” (BZ) for burrs or scoring damage. Light grinding or polishing may be required.

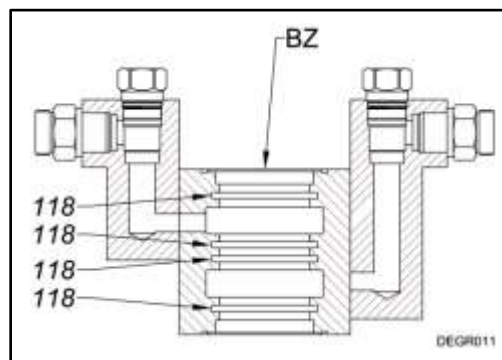

Figure 4

# ROTARY JOINT MAINTENANCE

## REPLACEMENT OF THE SEALS IN THE ROTARY JOINT

### Step 5

#### *Rotary joint reassembly:*

Lubricate the main seals (dg8), glide bearings (dg7) and o-rings (RR) with grease or NPK Assembly Lubricant. Install the main seals into the "Spindle Case" (BZ) first. Then install the first o-ring and glide bearing to the underside of the spindle case. Slide the "Spindle Case" over "Spindle" (CA). Then install second glide bearing and o-ring. Install the cover plate (CH) and three flat head socket screws (AF9). Make sure the counterbalance valve cartridge (cb1) is tight.

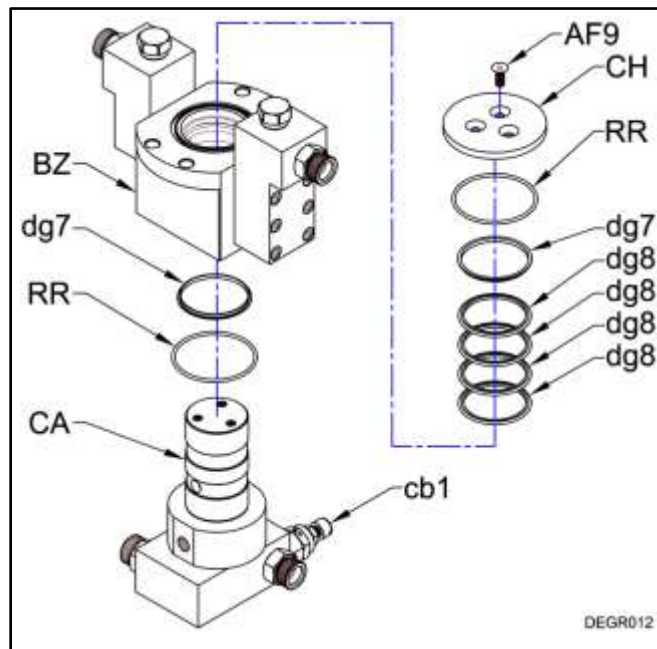

Figure 5



# TROUBLESHOOTING

## DETERMINE THE TYPE OF PROBLEM

Performance problems are classified as “**LOSS OF POWER**” OR “**LOSS OF CYCLE SPEED**” (*assuming the problem is not due to misapplication*).

### 1. LOSS OF POWER

NPK attachment grabbing forces are determined by the operating pressure settings.

### 2. LOSS OF CYCLE SPEED

NPK attachment cycle speed is determined by the hydraulic flow to the unit. The hydraulic installation circuit must be set to provide the correct oil flow.

## DETERMINE THE CAUSE OF THE PROBLEM

Technical problems are caused by either the NPK attachment or the hydraulic circuit (*carrier hydraulics or installation kit*). Checking the hydraulic pressure and flow will determine if the problem is in the Demolition Grab or the carrier. If the pressures and flow available to the Demolition Grab are correct, the problem is in the Demolition Grab.

## GUIDE FOR LOSS OF POWER (*relief valve checks*)

Loss of power can be caused by a low carrier relief valve setting or a low Demolition Grab relief setting. Verify the correct relief valve settings of the carrier and the Demolition Grab. Refer to the “**RELIEF VALVE CHECKING AND SETTING PROCEDURE**” and the troubleshooting chart.

## MEASURING OPERATING PRESSURES

### Tools and Equipment required:

Qty. 1 -Pressure gauge: 0 – 5,000 psi (0 – 350 bar), for arm close circuit.

Qty. 1 -Test port adapter: to fit #4 SAE female port in the NPK shut-off valve.

Qty. 1 -Test hose: rated for 5,000 psi (350 bar).

## RELIEF VALVE CHECKING AND SETTING PROCEDURE

Some hydraulic installation kits provide shut-off valves (k4) with test ports (k8) in both arm open (m4) and arm close (m3) hydraulic lines. Install pressure test hoses in both the arm open and arm close test ports.

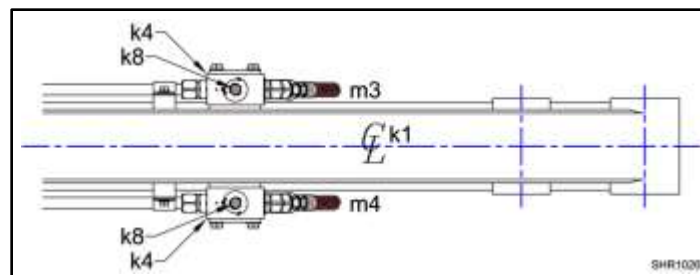

# TROUBLESHOOTING

## RELIEF VALVE CHECKING AND SETTING PROCEDURE

### A. THE CARRIER'S HYDRAULIC CIRCUIT RELIEF VALVE

Verify that the hydraulic circuit meets the Demolition Grab's (GZ) requirements; see "**SPECIFICATIONS**", pages 9 through 17.

1. Install a 0 – 5,000 psi (0 – 350 bar) pressure gauge (g8f) in the #4 SAE test port (k8) on the arm close side and a 0 – 5,000 psi (0 – 350 bar) pressure gauge (g8b) in the #4 SAE test port on the arm open side located in both shut off valves (k4) at the end of the stick.

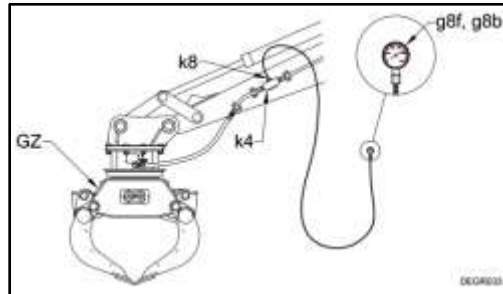

2. Turn the shut-off valves (k4) to the "**OFF**" position (k6).

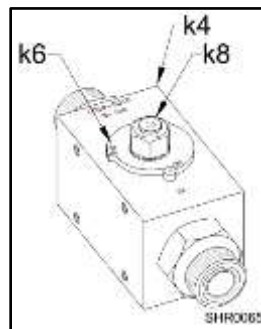

3. Start the carrier. Set the throttle to the "**FULL**" position. Actuate the hydraulic circuit to close the Demolition Grab's arms.

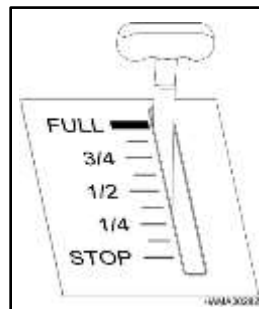

4. The pressure reading on the gauge should be a minimum of 500 psi (34 bar) above the Demolition Grab's relief valve setting, see "**SPECIFICATIONS**", pages 9 through 17. **NOTE:** If the carrier's relief is not set at a minimum of 500 psi (34 bar) above the Demolition Grab's relief, reset or replace at this time.

# TROUBLESHOOTING

## RELIEF VALVE CHECKING AND SETTING PROCEDURE

### B. DEMOLITION GRAB'S COUNTERBALANCE VALVE

After the carrier's hydraulic circuit has been verified, check the Demolition Grab's counterbalance valve setting.

1. With the 0 – 5,000 psi (0 – 350 bar) gauge in the arm close side and the 0 – 5,000 psi (0 - 350 bar) in the arm open side of the stick, turn the shut-off valves (k4) to the "ON" position (k5).

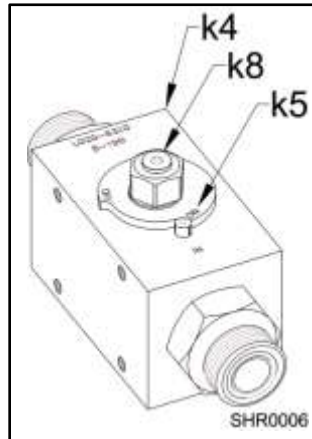

2. Start the carrier. Set the throttle to the full position then close the arms completely and hold for ten seconds. Check the psi (bar) reading on the gauge and compare to the Demolition Grab's specified counterbalance valve setting. If the reading is not per specification, see "**SPECIFICATIONS**", pages 9 through 17 and reset the counterbalance valve cartridge. If you are unable to reset the counterbalance, refer to the troubleshooting chart.

## COUNTERBALANCE VALVE LOCATION

The counterbalance valve cartridge (cb1) is located in the manifold block, which is part of the rotary joint assembly (BN). (See the unit's parts breakdown for the location of the rotary joint.)

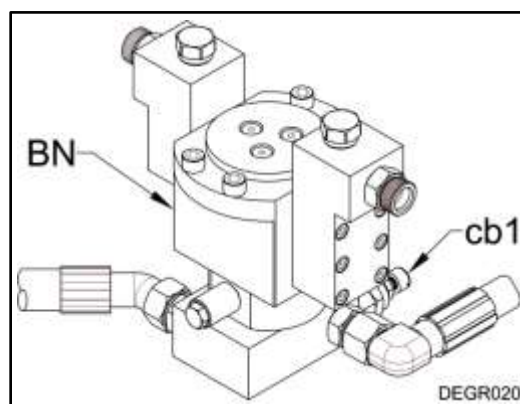

# TROUBLESHOOTING

## TROUBLESHOOTING CHART FOR LOW POWER

PROBLEM	CAUSE	CHECK	REMEDY
Operating pressure is less than 3,625 psi (250 bar).	Excavator hydraulic circuit relief valve.	Measure the excavator circuit relief valve pressure with the left hand shut-off valve closed.	Adjust or replace the excavator circuit relief valve.
	Attachment relief valves.	Measure the attachment relief valves with the shut-off valves open.	Replace the attachment relief valve.
		Check the relief valve cartridge for tightness.	Tighten the relief valve cartridge.
		Check the relief valve cartridge for mis-adjustment.	Re-adjust the relief cartridge.
		Check the o-rings and backup rings of the relief valve cartridge.	Replace the o-rings and backup rings of the relief valve cartridge.
		Check the seals between the open and close passages of the swivel manifold assembly.	Replace the seals in the swivel manifold assembly.
		Check the land areas for the seals in the swivel manifold assembly.	Repair the land areas or replace the spindle.

**NOTE:** *If additional assistance is required, call the NPK Service Department at (440) 232-7900.*

# TROUBLESHOOTING

## TROUBLESHOOTING FOR SLOW CYLINDER SPEED

The cycle times of the Demolition Grab are controlled by the flow provided by the hydraulic circuit of the carrier. The cycle times of the Demolition Grab are a direct result of the maximum published oil flow, see “**SPECIFICATIONS**”, pages 9 through 17.

**NOTE:** *If the jaws will not open or close, be sure the right and left shut-off valves are open.*

## CHECKING HYDRAULIC FLOW AT RATED PRESSURE

### Tools and Equipment required:

Qty. 1 -Pressure gauge: 0 – 5,000 psi (0 – 350 bar), for arm close circuit.

Qty. 1 -Test port adapter: to fit #4 SAE female port in the NPK shut-off valve.

Qty. 1 -Test hose: rated for 5,000 psi (350 bar).

Qty. 1 -Hydraulic flow meter: pressure loading type, 0 – 100 gpm (0 – 380 lpm) minimum capacity.

## PROCEDURE FOR CHECKING HYDRAULIC FLOW AT RATED PRESSURE

1. Install a pressure gauge in the shut-off valve of the close side (left) of the hydraulic circuit.

2. Install; a flow meter (t36) between the Demolition Grab (GZ) close and open lines as shown.

**NOTE:** Typically, the arm close line (m3) is on the left (*from the operator's*) seat and arm open (m4) is on the right.

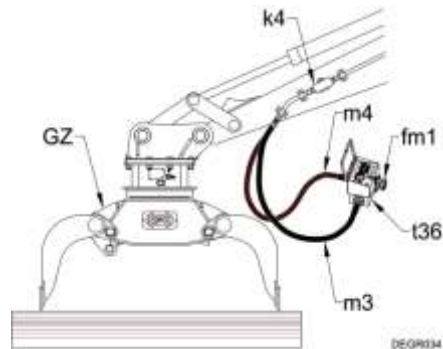

3. To determine return line pressure (*pressure drop*) open both shut-off valves (k4) and energize the arm close circuit. Measure the pressure with the load valve (fm1) of the flow meter in the full open position.

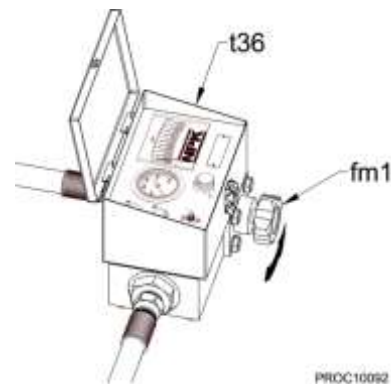

# TROUBLESHOOTING

## PROCEDURE FOR CHECKING HYDRAULIC FLOW AT RATED PRESSURE

4. To determine the available flow and relief valve setting of the carrier, follow the following procedure.
  - a. Adjust the load valve on the flow meter to zero restriction. Start the carrier. Set the throttle to the **“FULL”** position.



- b. Energize the close hydraulic circuit. Adjust the flow meter load valve until the system reaches about 1,000 psi (70 bar). Warm the hydraulic system of the carrier to normal operating temperature.

- c. With the engine at full throttle and the flow meter set at zero pressure, energize the close circuit. Turn in the loading valve adjustment knob and record pressure and flow at regular intervals on graph paper. Record pressure on one axis of the graph and flow on the other. Increase pressure until the relief valve setting of the carrier is reached. This is the circuit flow chart.

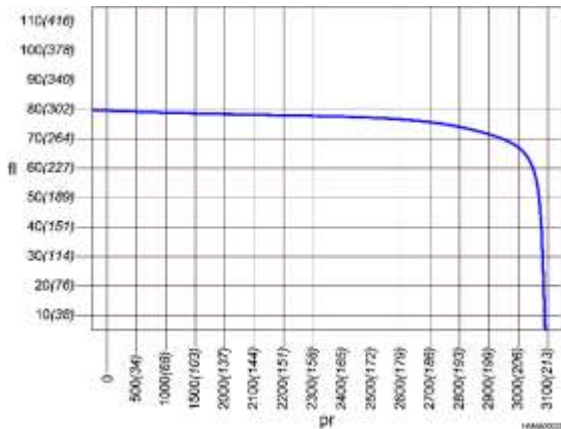

<b>fl</b>	Hydraulic Flow
<b>pr</b>	Pressure (psi)

- d. Then set the flow meter at 1,000 psi (70 bar) and check flow. See **“SPECIFICATIONS”** pages 9 through 17, for the correct flow for your Demolition Grab. If the reading on the flow meter does not match the Demolition Grab specification, adjust the flow of the carrier.

- e. If the cycle speed is still too slow, refer to the slow cylinder speed troubleshooting chart on the next page.

# TROUBLESHOOTING

## TROUBLESHOOTING CHART FOR SLOW CYLINDER SPEED

PROBLEM	CAUSE	CHECK	REMEDY
Slow cylinder speed. Operating pressure okay. 3,625 psi (250 bar) minimum.	Carrier flow setting is low.	Check flow output of attachment hydraulic circuit at 1000 psi (69 bar).	Adjust control valve flow adjustment of carrier
			Repair or replace the carrier's pump
			Check attachment cylinder packing. Replace if required.
Slow cylinder speed. Operating pressure not okay. Less than 3,625psi (250 bar)	Carrier relief set too low. Set below 3,800 psi (262 bar).	Measure the excavator circuit relief valve pressure with the shut-off valve closed.	Adjust or replace the carrier's circuit relief valve.
	Attachment counterbalance valve cartridge.	Check the counterbalance valve cartridge for tightness	Tighten the counterbalance valve cartridge.
		Check the o-rings and backup rings of the counterbalance valve cartridge.	Replace the o-rings and backup rings of the counterbalance valve cartridge.

**NOTE:** *If additional assistance is required, call the NPK Service Department at (440) 232-7900.*

## JAW DRIFT

1. Some drift may be experienced depending on the Demolition Grab's position.
2. Acceptable drift may occur over a number of minutes.
3. Rapid drift may indicate a problem with the Demolition Grab's cylinder, rotary joint assembly or the carrier's hydraulic circuit.

## TO DETERMINE IF THE JAW DRIFT IS OCCURRING FROM A BAD CYLINDER OR THE CARRIER

1. Remove the hoses from the joint fittings on the outside of the Demolition Grab's frame and close the shut-off valves on the carrier.
2. Cap the joint fittings (#12 JIC).  
If the jaw drifts, the problem is coming from the Demolition Grab's cylinder or rotary joint assembly. If no drift occurs, the problem is in the carrier's main control valve. Drift due to the carrier's main control valve internal leakage, may be inherent to the carrier and may not be solvable.

# TROUBLESHOOTING

## TROUBLESHOOTING FOR SLOW ROTATION SPEED

### ROTATION

The rotation speed is a direct result of the amount of flow (gpm/lpm) supplied by the rotation circuit of the carrier. The chart on the following page lists the approximate flow required.

MODEL	OIL FLOW ROTATION		PRESSURE ROTATION	
	gpm	(lpm)	psi	(bar)
DG-4	3 - 6	(12 - 23)	1,500 - 2,000	(103 - 138)
DG-6	2.5 - 4	(10 - 15)	1,450 - 1,885	(100 - 130)
DG-9	3 - 4	(12 - 15)	1,450 - 1,885	(100 - 130)
DG-14	5 - 8	(20 - 30)	1,450 - 2,030	(100 - 140)
DG-16	5 - 8	(20 - 30)	1,450 - 2,030	(100 - 140)
DG-20/20A	5 - 8	(20 - 30)	1,450 - 2,030	(100 - 140)
*DG-20/20A	8 - 13	(30 - 50)	1,450 - 2,030	(100 - 140)
DG-25	5 - 8	(20 - 30)	1,450 - 2,030	(100 - 140)
*DG-25	8 - 13	(30 - 50)	1,450 - 2,030	(100 - 140)
DG-30/30A	5 - 8	(20 - 30)	1,450 - 2,030	(100 - 140)
*DG-30/30A	8 - 13	(30 - 50)	1,450 - 2,030	(100 - 140)
DG-40/40A	5 - 8	(20 - 30)	1,450 - 2,030	(100 - 140)
*DG-40/40A	8 - 13	(30 - 50)	1,450 - 2,030	(100 - 140)
*DG-50	8 - 13	(30 - 50)	1,450 - 2,320	(100 - 160)

\*Denotes dual motors

Adjust the rotation flow so that it is within the guidelines shown for the model being tested.

Flows are checked at a normal operating pressure of 1,000 psi (70 bar). Cross port relief valves rated at 2,500 psi (172 bar) are included in the hydraulic motor.



Excessive rotation speed will result in damage to the hydraulic motor, gearbox, or bearing.

### MEASURING ROTATION PRESSURES

#### Tools and Equipment Required

Qty. 1 -Pressure gauge: 0 – 3,000 psi (0 – 210 bar)

Qty. 1 -Gauge adapter fitting: 1/4" npt female x #6 JIC male  
(NPK part number K023-6690)

Qty. 2 -Swivel run tee fittings: #8 JIC

Qty. 2 -Test hoses: rated for 3,000 psi (210 bar); #8 JIC female swivel one end and #6 JIC female swivel the other end.



# TROUBLESHOOTING

## TROUBLESHOOTING FOR SLOW ROTATION SPEED

### ROTATION PRESSURE CHECKING PROCEDURE

1. Install gauges in the rotation circuit lines.
2. Position the Demolition Grab so that it will not rotate.
3. Attempt to rotate the unit in both directions. Each gauge should read 2,000 psi (138 bar).

### TROUBLESHOOTING CHART FOR ROTATION

PROBLEM	CAUSE	CHECK	REMEDY
Unit will not rotate	Low or no flow.	Check hydraulic flow. <i>Reference hydraulic flow chart above.</i>	Adjust the carrier's flow to the attachment.
	Pressure setting of cross port relief valves (ma4).	Check cross port relief valve settings. <i>See procedure above.</i>	Adjust the cross-port relief valves on the rotation holding valve.
			Replace cross port relief valves.
Broken pinion gear or hydraulic motor shaft.	Check pinion gear and hydraulic motor shaft.	Replace hydraulic motor or pinion gear.	
Unit will not hold position.	Pressure setting of cross port relief valves.	Check cross port relief valve settings. <i>See procedure above.</i>	Adjust the cross-port relief valves on the rotation holding valve.
			Replace cross port relief valves.
	Broken pinion gear or hydraulic motor shaft.	Check pinion gear and hydraulic motor shaft.	Replace hydraulic motor or pinion gear.

# TROUBLESHOOTING

## ADJUSTMENT OF ROTATION SPEED

DG-9, DG-14, DG-16 UNITS AND DG-20/20A, DG-25, DG-30/30A AND DG-40/40A UNITS WITH THE SINGLE MOTOR OPTION

The rotation speed can be adjusted clockwise and counterclockwise independently from each other.

### PROCEDURE

1. Remove both covers (s9) from the side of the swivel top (m27).
2. When the covers are removed, two flow regulators (fr) will be visible.

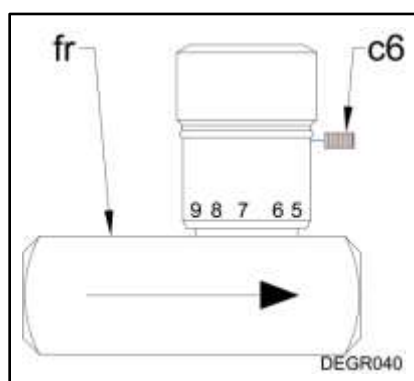

3. These regulators are locked with a (3/32") locking screw (c6). The screw must be loosened before the flow regulators can be adjusted.
4. By turning the adjustment knobs, you can either slow down or accelerate the rotation speed.

**NOTE:** Be sure to tighten the locking screw when adjustment of the rotation speed is completed.

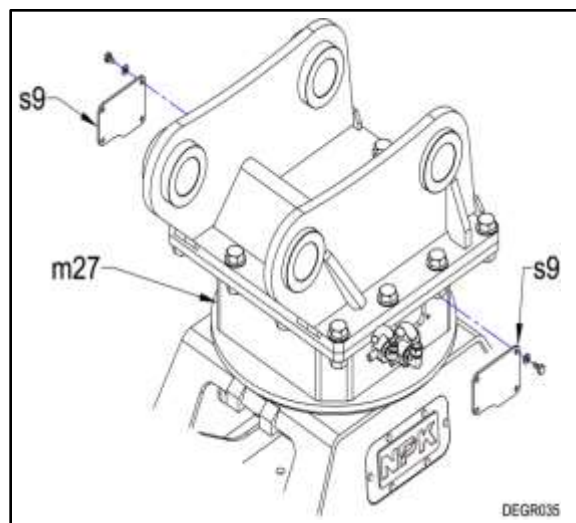

# FASTENER TORQUE CHARTS

These torque charts are to be used with the specific Demolition Grab Parts Manual for the unit being repaired.

All fasteners will require lube or medium strength thread adhesive. Bolts must have their threads wire brushed or cleaned with a thread die; then cleaned with solvent; then cleaned with compressed air. Threaded holes must be cleaned with a tap; then cleaned with solvent; then cleaned with compressed air.

Do not use anti-seize compound on any fasteners, unless otherwise noted.

MODEL	TOP COVER - HHCS			
	PART NO.	BOLT DIA	ft. lbs.	(Nm)
DG-4	N/A	N/A	N/A	N/A
DG-6	N/A	N/A	N/A	N/A
DG-9	N/A	N/A	N/A	N/A
DG-14	N/A	N/A	N/A	N/A
DG-16	71008020	M8	19	(25)
DG-20/20A	71008020	M8	19	(25)
DG-25	71008020	M8	19	(25)
DG-30/30A	71008020	M8	19	(25)
DG-40/40A	71008020	M8	19	(25)
DG-50	71008020	M8	19	(25)

MODEL	COVER PLATE - HHCS			
	PART NO.	BOLT DIA.	ft. lbs	(Nm)
DG-4	71008020	M8	19	(25)
DG-6	71008020	M8	19	(25)
DG-9	71010020	M10	37	(50)
DG-14	71010020	M10	37	(50)
DG-16	71010020	M10	37	(50)
DG-20/20A	71010020	M10	37	(50)
DG-25	71010020	M10	37	(50)
DG-30/30A	71010020	M10	37	(50)
DG-40/40A	71010020	M10	37	(50)
DG-50	71010020	M10	37	(50)

MODEL	SAFETY BAR - HHCS			
	PART NO.	BOLT DIA	ft. lbs.	(Nm)
DG-4	71012040	M12	81	(110)
DG-6	71016040	M16	207	(280)
DG-9	71020040	M20	406	(550)
DG-14	71020040	M20	406	(550)
DG-16	71020040	M20	406	(550)
DG-20/20A	71020040	M20	406	(550)
DG-25	71020040	M20	406	(550)
DG-30/30A	71020040	M20	406	(550)
DG-40/40A	71020040	M20	406	(550)
DG-50	71020045	M20	406	(550)

# FASTENER TORQUE CHARTS

---

MODEL	SUPPORT BRACKET - HHCS			
	PART NO.	BOLT DIA.	ft. lbs	(Nm)
DG-4	N/A	N/A	N/A	N/A
DG-6	74012055	M12	81	(110)
DG-9	71012025	M12	81	(110)
DG-14	N/A	N/A	N/A	N/A
DG-16	71012020	M12	81	(110)
DG-20/20A	71012020	M12	81	(110)
DG-25	71012020	M12	81	(110)
DG-30/30A	71012020	M12	81	(110)
DG-40/40A	71012020	M12	81	(110)
DG-50	71012020	M12	81	(110)

MODEL	CUTTER - HHCS			
	PART NO.	BOLT DIA.	ft. lbs	(Nm)
DG-4	97600005	M12	81	(110)
DG-6	98500077	M16	207	(280)
DG-9	98500077	M16	207	(280)
DG-14	97600033	M20	332	(450)
DG-16	97600033	M20	332	(450)
DG-20/20A	97600033	M20	332	(450)
DG-25	97600001	M20	332	(450)
DG-30/30A	97600001	M20	332	(450)
DG-40/40A	97600001	M20	332	(450)
DG-50	97600001	M20	332	(450)

MODEL	SWIVEL SUPPORT - HHCS			
	PART NO.	BOLT DIA.	ft. lbs	(Nm)
DG-4	N/A	N/A	N/A	N/A
DG-6	71010025	M10	44	(60)
DG-9	71010025	M10	44	(60)
DG-14	74010016	M10	44	(60)
DG-16	71012045	M12	81	(110)
DG-20/20A	71012045	M12	81	(110)
DG-25	71012045	M12	81	(110)
DG-30/30A	71012045	M12	81	(110)
DG-40/40A	7101245	M12	81	(110)
DG-50	71012045	M12	81	(110)

# FASTENER TORQUE CHARTS

---

MODEL	PIN LOCK PLATE - HHCS			
	PART NO.	BOLT DIA.	ft. lbs	(Nm)
DG-4	N/A	N/A	N/A	N/A
DG-6	N/A	N/A	N/A	N/A
DG-9	N/A	N/A	N/A	N/A
DG-14	74012025	M12	96	(130)
DG-16	74012025	M12	96	(130)
DG-20/20A	74012025	M12	96	(130)
DG-25	74012025	M12	96	(130)
DG-30/30A	74012025	M12	96	(130)
DG-40/40A	74012025	M12	96	(130)
DG-50	74012025	M12	96	(130)

MODEL	MOTOR MOUNTING - HHCS			
	PART NO.	BOLT DIA.	ft. lbs	(Nm)
DG-4	N/A	N/A	N/A	N/A
DG-6	74012030	M12	96	(130)
DG-9	74012050	M12	96	(130)
DG-14	74012060	M12	96	(130)
DG-16	74012060	M12	96	(130)
DG-20/20A	74012060	M12	96	(130)
DG-25	74012060	M12	96	(130)
DG-30/30A	74012060	M12	96	(130)
DG-40/40A	74012060	M12	96	(130)
DG-50	74012060	M12	96	(130)

MODEL	PINION GEAR SET SCREW			
	PART NO.	BOLT DIA.	ft. lbs	(Nm)
DG-4	N/A	N/A	N/A	N/A
DG-6	98500946	M8	6	(8)
DG-9	98500946	M8	6	(8)
DG-14	98500647	M10	7	(10)
DG-16	98500647	M10	7	(10)
DG-20/20A	98500647	M10	7	(10)
DG-25	98500647	M10	7	(10)
DG-30/30A	98500647	M10	7	(10)
DG-40/40A	98500647	M10	7	(10)
DG-50	98500647	M10	7	(10)

**\*Medium strength Loctite must be used.**

# FASTENER TORQUE CHARTS

---

MODEL	SLEWING RING			
	PART NO.	BOLT DIA.	ft. lbs	(Nm)
DG-4	N/A	N/A	N/A	N/A
DG-6	74012050	M12	96	(130)
DG-9	74012060	M12	96	(130)
DG-14	74016055	M16	258	(350)
	74016070	M16	258	(350)
DG-16	74016075	M16	258	(350)
DG-20/20A	74016075	M16	258	(350)
	74016070	M16	258	(350)
DG-25	74016075	M16	258	(350)
	74016070	M16	258	(350)
DG-30/30A	74016080	M16	258	(350)
	74016090	M16	258	(350)
DG-40/40A	74016080	M16	258	(350)
	74016090	M16	258	(350)
DG-50	74016080	M16	258	(350)
	74016090	M16	258	(350)

**\*DO NOT use Loctite on slewing ring bolts.**

MODEL	TOP BRACKET		
	BOLT DIA.	ft. lbs	(Nm)
DG-4	3/8"	108	(146)
DG-6	3/8"	108	(146)
DG-9	3/4"	280	(379)
DG-14	3/4"	280	(379)
DG-16	1"	750	(1015)
DG-20/20A	1"	750	(1015)
DG-25	1-1/4"	1500	(2030)
DG-30/30A	1-1/4"	1500	(2030)
DG-40/40A	1-1/4"	1500	(2030)
DG-50	1-1/4"	1500	(2030)

MODEL	SWIVEL MANIFOLD			
	PART NO.	BOLT DIA.	ft. lbs	(Nm)
DG-4	74010035	M10	52	(70)
DG-6	71010025	M10	52	(70)
DG-9	74010025	M10	52	(70)
DG-14	74012035	M12	96	(130)
DG-16	74012040	M12	96	(130)
DG-20/20A	74012040	M12	96	(130)
DG-25	74012040	M12	96	(130)
DG-30/30A	74012040	M12	96	(130)
DG-40/40A	74012040	M12	96	(130)
DG-50	74012040	M12	96	(130)

# PINION GEAR INSTALLATION

Insert the key (c7) into the slot on the motor shaft. Next, slide the pinion gear (BR) onto the shaft. Lastly, apply a medium strength Loctite on the set screw (c6) and torque the set screw (c6) using the chart in the fastener torque section of this manual.

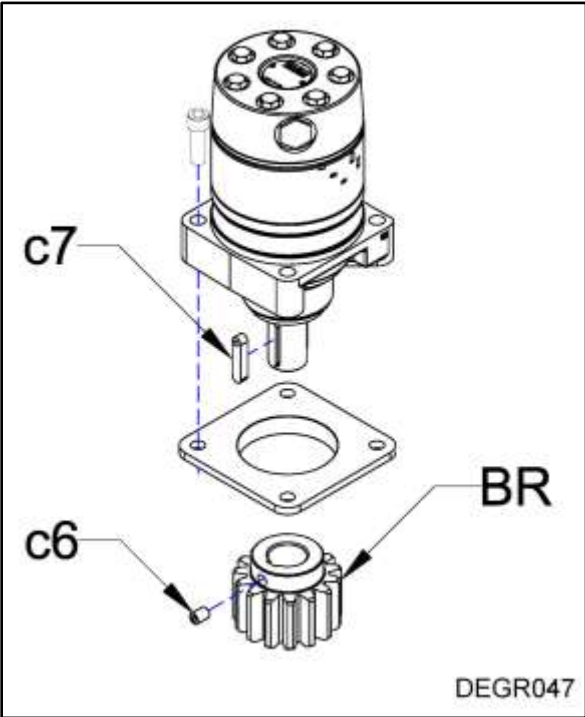

# CYLINDER TORQUE SPECIFICATIONS

---

## ROD NUT AND PISTON TORQUES

The torques listed below, are for the rod nut (c1) and piston (c2) used in the cylinder assembly for the NPK Demolition Grab. When assembling during rebuild, it is also recommended that thread adhesive is used to ensure complete clamping.

	TORQUE	
	ft. lbs.	(Nm)
<b>PISTON (c2)</b>	1106	(1500)
<b>ROD NUT (c1)</b>	29.5	(40)

Apply a small amount of thread adhesive to the set screw (c6) before installing.

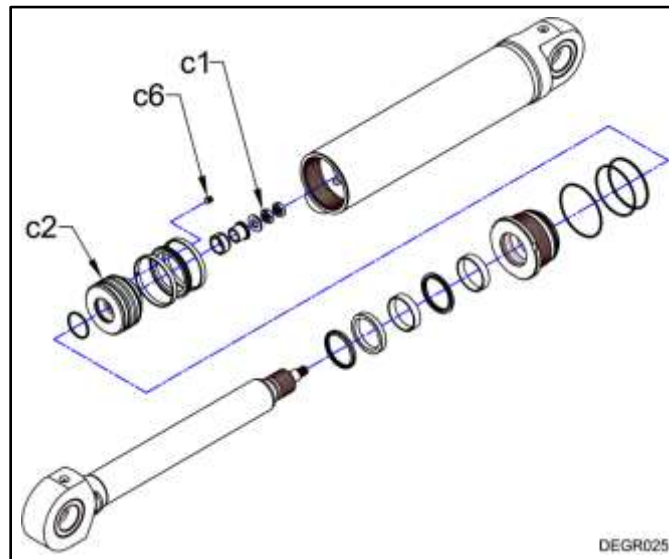



# CONVERT FROM DUAL MOTOR TO SINGLE MOTOR (DG20, DG30, DG40)

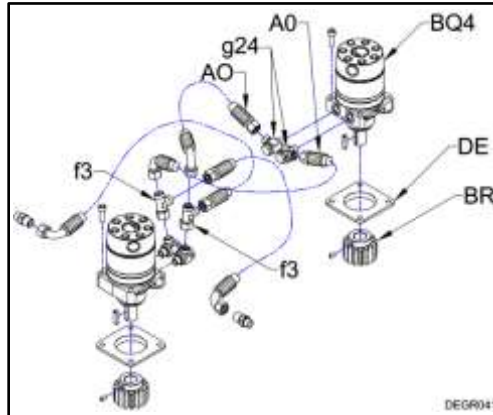

## PARTS TO REMOVE

<b>AO</b>	98500849	HOSE ASSEMBLY
<b>BQ4</b>	9850201	HYDRAULIC MOTOR
<b>BR</b>	98600640	PINION GEAR
<b>DE</b>	98601199	MOTOR PLATE
<b>f3</b>	98500155	TEE
<b>g24</b>	97600055	SWIVEL ELBOW

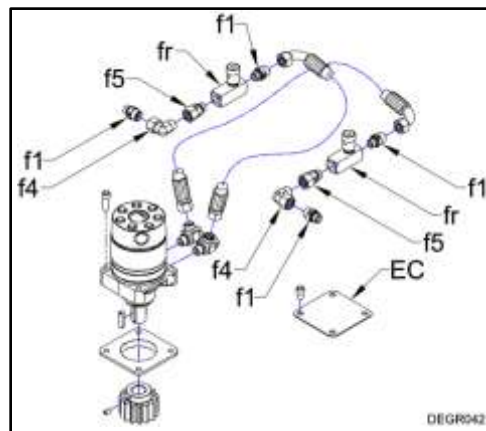

## PARTS TO ADD

<b>EC</b>	98601233	COVER
<b>f1</b>	97600043	ADAPTOR FITTING
<b>f4</b>	97600046	90° ADAPTOR
<b>f5</b>	97600044	ADAPTOR FITTING
<b>fr</b>	98500241	FLOW VALVE

# KEYWORDS FOR COMMON DEMOLITION GRAB COMPONENTS

## DG16 SHOWN

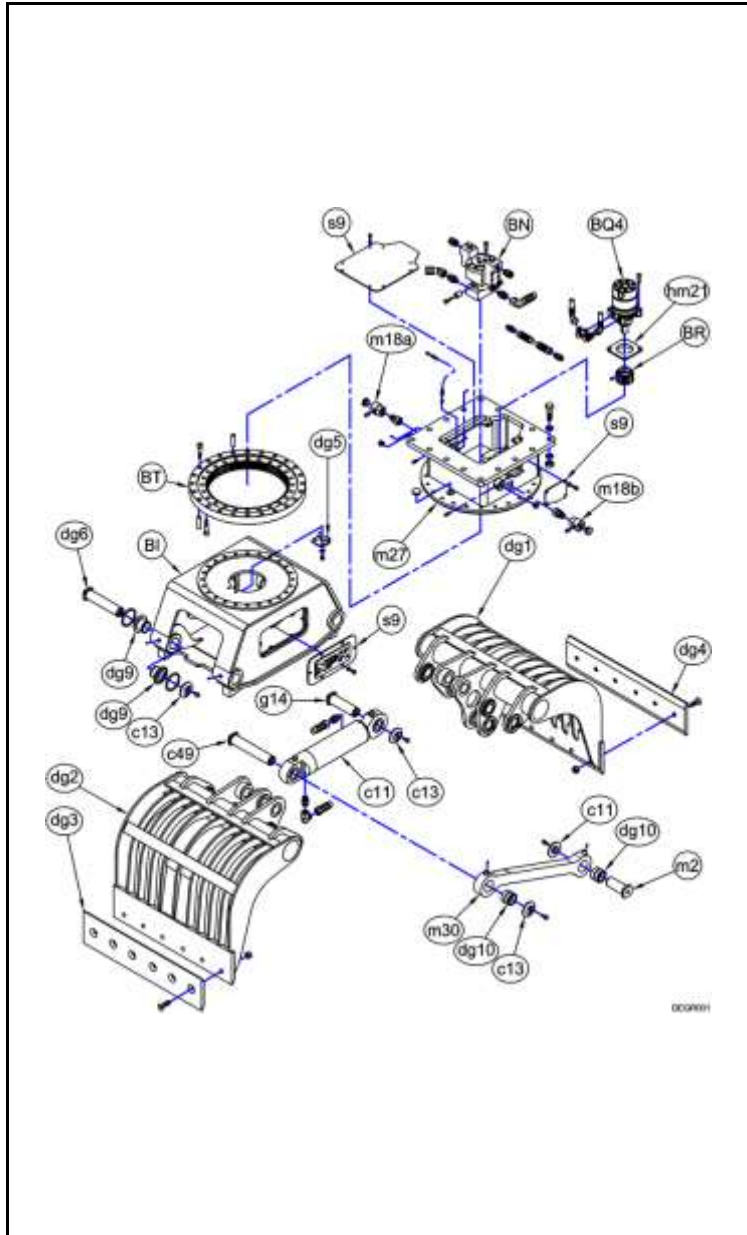

<b>BI</b>	MAIN FRAME
<b>BN</b>	ROTARY JOINT ASSEMBLY
<b>BQ4</b>	HYDRAULIC MOTOR
<b>BR</b>	PINION GEAR
<b>BT</b>	SLEWING RING
<b>c11</b>	CYLINDER
<b>c13</b>	PIN LOCK PLATE
<b>c49</b>	PIN ( <i>cylinder</i> )
<b>dg1</b>	DRIVE ARM
<b>dg10</b>	LINK BUSHING
<b>dg2</b>	ARM
<b>dg3</b>	CUTTER ( <i>sharp</i> )
<b>dg4</b>	CUTTER ( <i>blunt</i> )
<b>dg5</b>	SUPPORT BRACKET
<b>dg6</b>	ARM PIN
<b>dg9</b>	FRAME BUSHING
<b>g14</b>	PIN ( <i>cylinder rod end</i> )
<b>hm21</b>	MOTOR MOUNTING FLANGE
<b>m2</b>	LINK PIN
<b>m18a</b>	JOINT FITTING ( <i>close</i> )
<b>m18b</b>	JOINT FITTING ( <i>open</i> )
<b>m27</b>	SWIVEL FLAT TOP
<b>m30</b>	LINK
<b>s9</b>	COVER

# WARRANTY STATEMENTS

## **NPK** WARRANTY DEMOLITION GRAB

"Use Genuine NPK Parts" 6/17

**APPLICATION FOR WARRANTY MUST BE MADE WITHIN 30 WORKING DAYS OF FAILURE / REPAIR.**

**BASE WARRANTY (12 months)**

NPK CONSTRUCTION EQUIPMENT, INC. ("NPK") warrants for twelve (12) months following first use, demo, or delivery to the original end user, that the NPK Demolition Grab to be free from defects in material and workmanship as originally supplied under normal use and maintenance.

**THIS WARRANTY DOES NOT APPLY TO:**

- Items considered to be wear items such as secondary attachment, cutter/wear bar, swivel adaptor, seals, bolts, nuts, hydraulic hoses, fittings.

---

**NPK RESPONSIBILITY**

NPK will, at its option, repair or replace with a new or reconditioned part, any warranted part that fails by reason of defective material or workmanship, free of charge delivered to a place of business of an authorized NPK Dealer. Note: Parts replaced under warranty become the property of NPK.

During the twelve (12) month warranty period, NPK will pay the cost of labor at 75% of the posted shop rate that is necessary to install any replacement part during normal working hours. Overtime and travel expenses will not be reimbursed.

**USER RESPONSIBILITY**

- *Photos must accompany all warranties submitted to NPK.*
- All parties associated with the installation, operation or repairs of the NPK DEMOLITION GRAB assumes responsibility to read, understand, and comply with NPK's written **INSTALLATION, OPERATOR and SERVICE INSTRUCTIONS.**
- Returning Warranty Registration to NPK at the time of installation.
- All costs associated with transporting the NPK DEMOLITION GRAB and/or the base carrier to an authorized NPK Dealer or authorized location for repairs covered under the base warranty.
- Supplying photos or additional information regarding a failure.

**THESE WARRANTIES DO NOT COVER FAILURES RESULTING FROM:**

- Installation, alteration, operation, maintenance, repair or storage which NPK judges to be improper.
- Not performing **DAILY VISUAL INSPECTIONS** as specified in the NPK DEMOLITION GRAB INSTRUCTION MANUAL.
- Exceeding the maximum wear limits of jaw wear plates as specified in the NPK Instruction Manual.
- Exposure to extreme heat.
- Operation after discovery of damaged or worn parts that exceed NPK's maximum limits.
- Unreasonable delay in making repairs after being notified of a potential product problem.

**THESE WARRANTIES SPECIFICALLY EXCLUDE:**

- Installation not approved by NPK.
- Replacement due to normal wear.
- Repairs not made by an authorized NPK Dealer or agent of NPK.
- Use of parts not sold by NPK. **THE USE OF "WILL FIT" PARTS WILL VOID ALL NPK WARRANTIES.**
- Labor charges deemed excessive by NPK.
- Shipping charges in excess of those which are usual and customary. (Air freight, unless pre-approved, will not be covered.)
- Duties, brokerage fees, and local taxes.

**WARRANTY REPAIRS DO NOT EXTEND THE STANDARD WARRANTY PERIOD.**

**LIMITATIONS AND EXCLUSIONS**

Violation of any federal, provincial, state or local laws, ordinances, rules or regulations, or removal or alteration of product serial numbers void NPK's written product warranties. *Application for warranty must be made within 30 days of failure / repair.*

**THIS PRODUCT MUST BE USED IN A SAFE AND LAWFUL MANNER IN COMPLIANCE WITH APPLICABLE OSHA REGULATIONS.**

The written product warranties made by NPK set forth NPK's only obligations with respect to any claims of failure, defects or deficiencies in products sold by NPK. **NPK MAKES NO OTHER WARRANTIES OR REPRESENTATIONS WHATSOEVER, EXPRESS OR IMPLIED, OF THE QUALITY, PERFORMANCE, DURABILITY, MATERIALS, WORKMANSHIP, SUITABILITY, CONDITION, DESIGN OR UTILITY OF PRODUCTS SOLD BY NPK, INCLUDING, WITHOUT LIMITATION, IMPLIED WARRANTIES OF MERCHANTABILITY AND FITNESS. ALL SUCH OTHER WARRANTIES AND REPRESENTATIONS BEING HEREBY EXPRESSLY EXCLUDED. NPK SHALL NOT BE LIABLE FOR SPECIAL, INCIDENTAL OR CONSEQUENTIAL DAMAGES, INCLUDING, WITHOUT LIMITATION, COSTS, LOSSES OR LIABILITIES ON ACCOUNT OF DELAY OR DOWNTIME.**

**DISCLAIMER REGARDING OTHER REPRESENTATIONS OR WARRANTIES**

No person is authorized to grant any other warranties or to assume any other liability on NPK's behalf unless made or assumed in writing by an officer of NPK. No person is authorized to grant any warranties or to assume any liabilities on the seller's behalf unless made or assumed in writing by the seller.

Internet: [www.npkoe.com](http://www.npkoe.com)  
As used in this warranty the term NPK means NPK CONSTRUCTION EQUIPMENT, INC., WALTON HILLS, OHIO, U.S.A.

# WARRANTY STATEMENTS

"Use Genuine NPK Parts" 6/08

## **NPK** WARRANTY REPLACEMENT PARTS

**APPLICATION FOR WARRANTY MUST BE MADE WITHIN 30 WORKING DAYS OF FAILURE / REPAIR.**

### REPLACEMENT PARTS WARRANTY (90 days)

NPK CONSTRUCTION EQUIPMENT, INC. ("NPK") warrants that new Replacement Parts sold by NPK will be free from defects in material or workmanship for a period of ninety (90) days, starting from the date of installation. NPK Replacement Parts Warranty **does not** cover labor or travel expenses. Note: Unexpired New Product Warranty has priority over Replacement Parts Warranty.

**THIS WARRANTY DOES NOT APPLY TO:**

- Wear items such as upper and lower tool bushings, impact ring, retaining bars and pins.
- Tools (covered under separate Tool Warranty).

---

#### NPK RESPONSIBILITY

NPK will, at its option, repair or replace with a new or reconditioned part, any warranted part that fails by reason of defective material or workmanship, free of charge delivered at a place of business of an NPK Dealer. Note: Parts replaced under warranty become the property of NPK.

#### USER RESPONSIBILITY

- **Photos must accompany all warranties submitted to NPK. These photos can be 35mm, polaroid, or digital.**
- The installer, user, operator, repairer, assumes responsibility to read, understand and comply with NPK's written INSTALLATION, OPERATOR and SERVICE INSTRUCTIONS.
- All labor costs.
- Any expense incurred by field repair.
- Supplying a hydraulic oil sample from the carrier machine upon request by NPK.

#### THESE WARRANTIES DO NOT COVER FAILURES RESULTING FROM:

- Installation, alteration, operation, maintenance, repair or storage which NPK judges improper.
- Not performing DAILY VISUAL INSPECTIONS and/or RETIGHTENING of fasteners after initial 20 operating hours after repair.
- Exceeding the tool and/or tool bushing wear limit.
- Underwater operation
- Operation after discovery of defective or worn parts.
- Unreasonable delay in making a repair after being notified of a potential product problem.

#### THESE WARRANTIES SPECIFICALLY EXCLUDE:

- Installations not approved by NPK.
- Replacement due to normal wear.
- Use of parts not sold by NPK. **THE USE OF "WILL FIT" PARTS WILL VOID ALL NPK WARRANTIES.**
- Parts shipping charges in excess of those which are usual and customary. (Air freight, unless pre-approved, will not be covered.)
- Duties, brokerage fees, and local taxes.

**WARRANTY REPAIRS DO NOT EXTEND THE STANDARD WARRANTY PERIOD.**

Internet: [www.npkce.com](http://www.npkce.com)  
As used in this warranty the term NPK means NPK CONSTRUCTION EQUIPMENT, INC., WALTON HILLS, OHIO, U.S.A.



---

**NPK** 7550 INDEPENDENCE DRIVE WALTON HILLS, OHIO 44146  
PHONE: 440-232-7900 FAX: 440-232-6294

---

© Copyright 2021 NPK Construction Equipment, Inc. [www.npkce.com](http://www.npkce.com) DG000-9600D Demolition  
Grab Instruction Manual 6-21 All Models.docx