

# NPK

## Dust Suppression

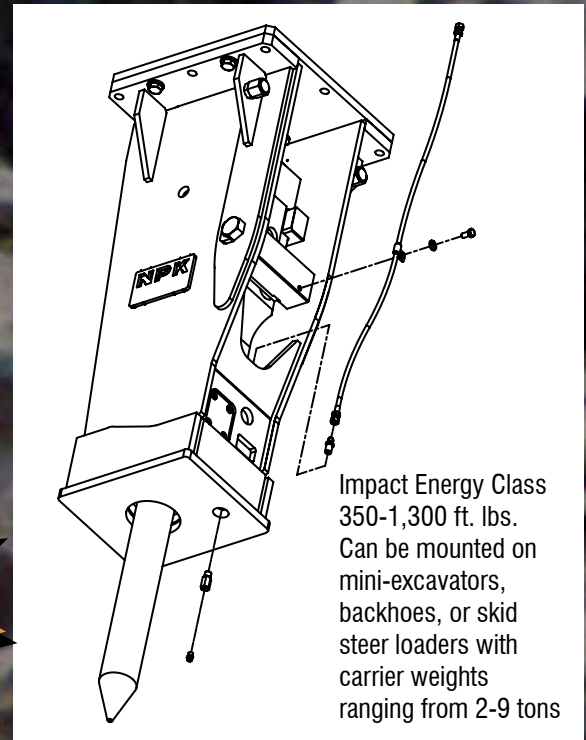

Available on  
PH-1, PH-2,  
PH-3 & PH-4  
with Enclosed  
Bracket



Impact Energy Class  
350-1,300 ft. lbs.  
Can be mounted on  
mini-excavators,  
backhoes, or skid  
steer loaders with  
carrier weights  
ranging from 2-9 tons

- **Water Spray Nozzle Integrated into Bracket**
- **Wide Spray Angle for Maximum Coverage**
- **Easy Access for Servicability**
- **Ready to be Connected to Water Supply**

***NPK ATTACHMENTS...designed, built and backed by NPK.***





# DUST SUPPRESSION

Ready to be Connected to Water Supply

NPK now offers an add-on water-ready kit for PH series hammers with enclosed brackets (PH1, PH2, PH3, and PH4 only). This system reduces dust at the point of impact in concrete, rock, or whatever surface is being broken, improving visibility at the breaking site and in the surrounding area. Silica dust can be significantly reduced through the use of wet methods, thus reducing concentrations in breathing air and workers' exposure. NPK's water-ready hammers help to make working environments safer and to meet OSHA silica dust reduction regulations.

An integrated water spray nozzle eliminates the need for manual spraying. Located in the bracket of the hammer, the nozzle is aimed at the point where the hammer's tool makes contact with the breaking area. This, combined with a wide spray angle, provides maximum dust suppression coverage. It helps to control airborne dust, including respirable crystalline silica, at the point of impact in two ways. Upon breaking, particles are sprayed with mist; this mist combines with particles which increases weight and leads them to drop back to the ground. Additionally, the mist douses the breaking area before impact, thus reducing the amount of dust or silica generated and hinders dust from rising back into the tool bushing.

These hammers come complete and ready to be connected to an appropriate water supply.

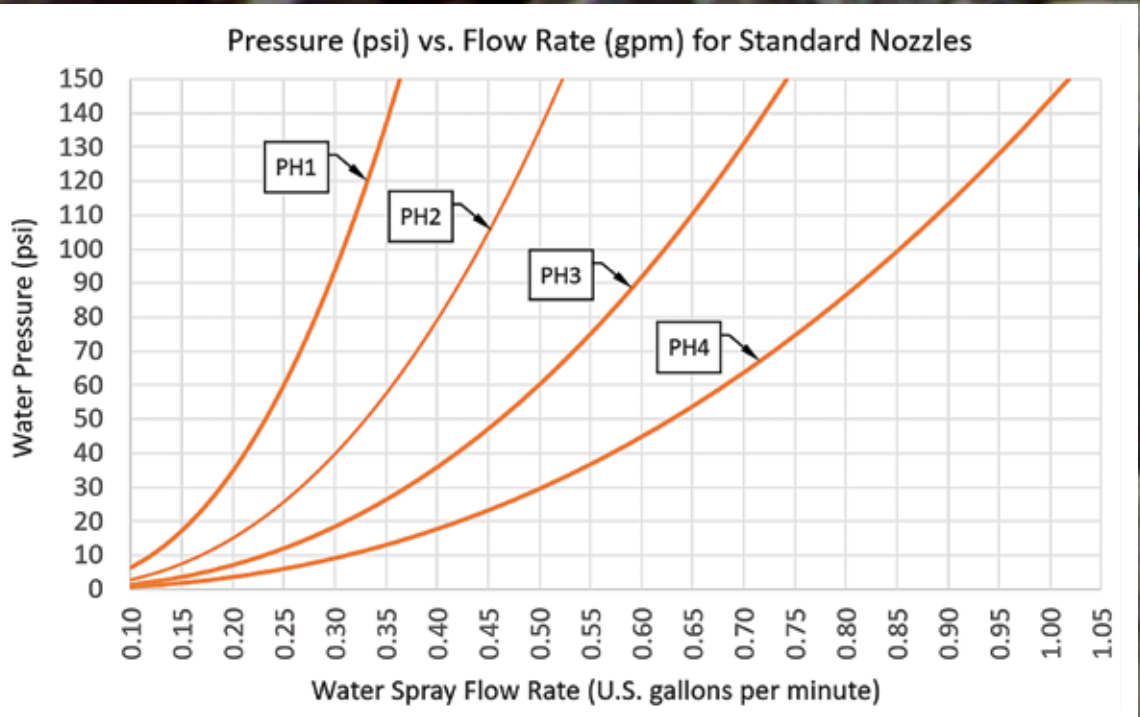

Wide spray angle for maximum coverage



**NPK Construction Equipment, Inc.**  
 7550 Independence Drive  
 Walton Hills, OH 44146-5541  
 Phone (440) 232-7900  
 Toll-free (800) 225-4379  
 Fax (440) 232-4382  
 Internet: [www.npkce.com](http://www.npkce.com)

Sold and Serviced by:

Each product sold by NPK is subject to an express written warranty. NPK makes no other warranty, express or implied, including any warranty of merchantability or fitness for any particular purpose. NPK is not liable for any incidental or consequential damages.