

NPK

Hydraulic Hammers



- *Hardest Hitting, Most Productive Hammer in the Industry*
- *Extensive Line with Models Ideal for Any Application*
- *Industry's Most Comprehensive Field Service Corps*
- *Extensive Parts Distribution System*
- *Network of Over 350 Distributor Outlets*
- *All Models Backed by Our 3 Year Limited Warranty*

NPK ATTACHMENTS...designed, built and backed by NPK.



Service, Parts and the Best Dealer Network

Hammers for an assortment of carriers: mini-excavators, skid steers, backhoes, loaders, and full size excavators

Whether it be for the smallest, most nimble of carriers to the largest of excavators, NPK maintains its commitment to incorporate the latest technological innovations into our entire hydraulic hammer product line. Utilizing state of the art computer modeling, NPK has designed a lighter weight hammer that delivers high impact energy and improves carrier balance.

- Gas powered piston creates more impact per blow than any hammer in the industry
- Eliminates bladder type accumulators that are prone to sudden failure & costly maintenance
- Only two moving parts means increased productivity and reliability
- Anti-blank firing (ABF) system prevents hammers from firing if the chisel is not loaded, minimizing wear. The result is safer, more efficient operations & longer hammer life.
- The round, rotating, tool retaining pin contributes to longer life and easy tool replacement
- Replaceable cylinder sleeves prevent wear to the main body and are an easy economical solution when rebuilding
- Separate ports for bushing lubrication and air for underwater applications

Durability and serviceability are two key advantages of NPK hydraulic hammers. When maintained and serviced regularly, NPK hammers can last over 20 years! NPK offers a variety of tool configurations to suit any application. Manufactured and tested to NPK's high standards of quality, NPK backs all models with the industry's best service and support staff. NPK maintains an extensive network of over 350 distributor outlets, the industry's most comprehensive field service corps, and an extensive parts distribution network to ensure you receive the best results with NPK hydraulic hammers.

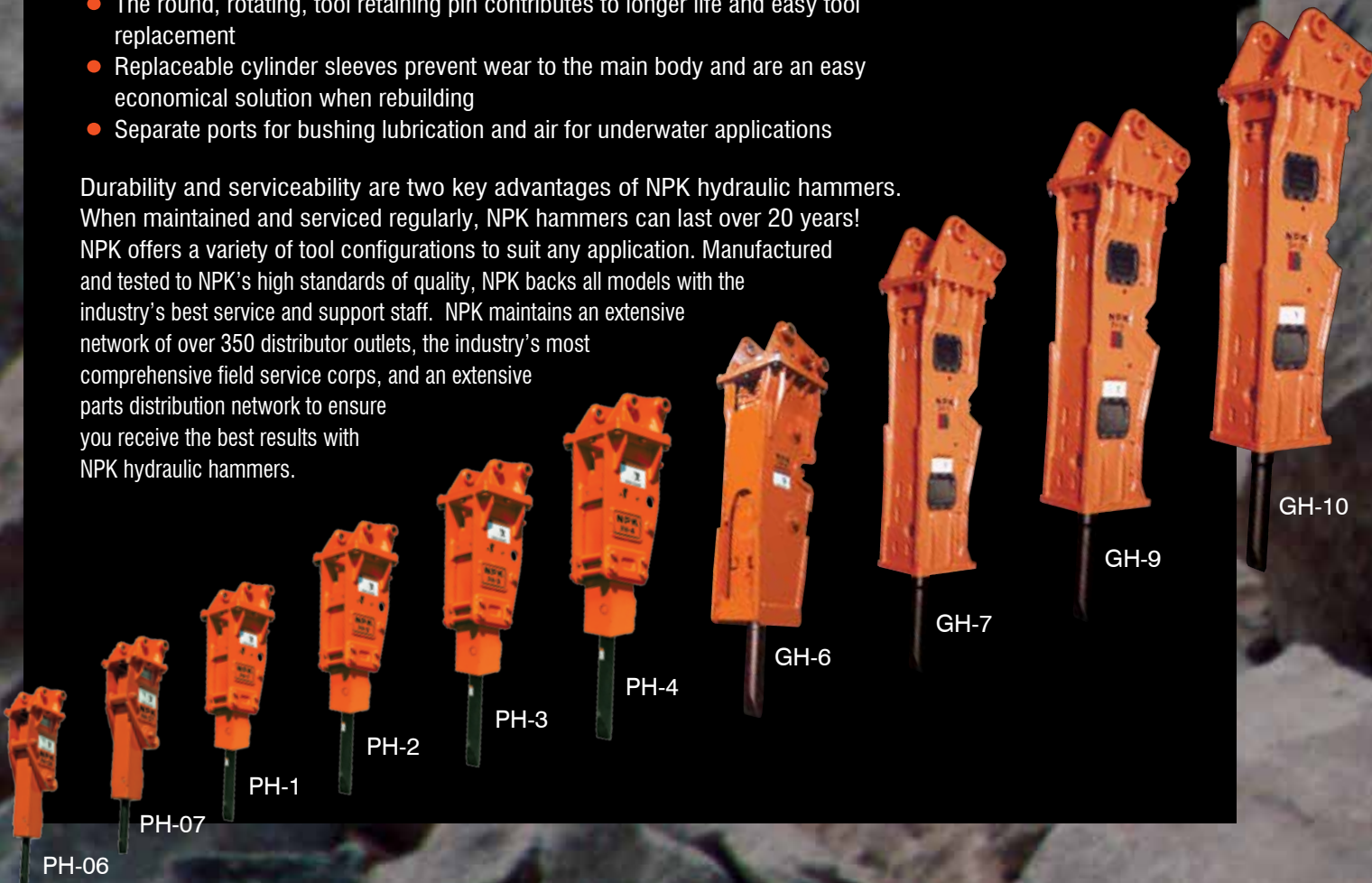

Durability, Productivity and Rebuildability

The Right Hammer for Every Job!



GH-12



GH-15



GH-18



GH-23



GH-30



GH-40



GH-50



NPK's enclosed hammer bracket option decreases operating noise beyond standard low noise brackets. Additionally, the enclosed hammer bracket is much narrower than our standard hammer bracket and may be preferred in some trenching applications.



Hammer mounted automatic lubrication systems are an optional add-on for models ranging from PH-3 to GH-40. This type of auto-lube is ideal for hammers being used by multiple machines. For dedicated hammer carriers NPK offers a carrier mounted auto-lube system.

Full serviceability of the industry's easiest, lowest cost, body-rebuild system

Hammers aren't meant to have an easy life and occasionally need to be rebuilt. An NPK hammer body can be re-sleeved for approximately 1/3rd the cost of competing brands when the body becomes worn or damaged. A typical hammer body can cost as much as 70% the cost of a new hammer so when you buy an NPK hammer you can expect an excellent return on your investment.

A better design that combines

• **EFFICIENCY** • **RELIABILITY** • **SERVICEABILITY**

Small Hammer Lineup – PH Series

NPK's newest line of small hammers, the PH series, is designed with over 45% fewer total parts than all previous NPK small hammer lines. Decreasing the number of components causes repair time, and therefore downtime, to be significantly reduced. The improved design starts with a fully sleeved one-piece hammer body, eliminating tie rods that were once necessary for fastening body components together. The restructured valve system is smaller, internal, and highly efficient. Replaceable sleeves ensure the hammer body doesn't undergo the wear and tear caused by repetitive firing of the piston. Additionally, the PH series "slip fit" style tool bushings are held in place by the retaining pin in the same manner as the tool. Because of this feature, bushings are quickly and easily replaced, even in the field, eliminating downtime due to tool bushing replacement. The PH series hammers are also equipped with our anti-blank firing feature providing longer component life.

PH Series hammers are available with either the standard hammer bracket or an optional enclosed bracket. This enclosed bracket design decreases operating noise and can be readily equipped with an optional water-ready dust suppression kit. Just connect to existing water supply.



PH-Series Hammers

- A. Gas charge valve
- B. Unique gas-charged piston maximizes hammer efficiency
- C. Simple, two-moving-parts design for reliability
- D. Anti-blank fire feature for long hammer life
- E. One-piece hammer body without tie rods
- F. Ports for automatic bushing lubrication and air for underwater use
- G. Quick-change tool system with single round retainer pin
- H. Replaceable cylinder sleeves for easy, economical rebuild
- I. Slip fit tool bushings for quick, easy replacement
- J. Variety of tool configurations available

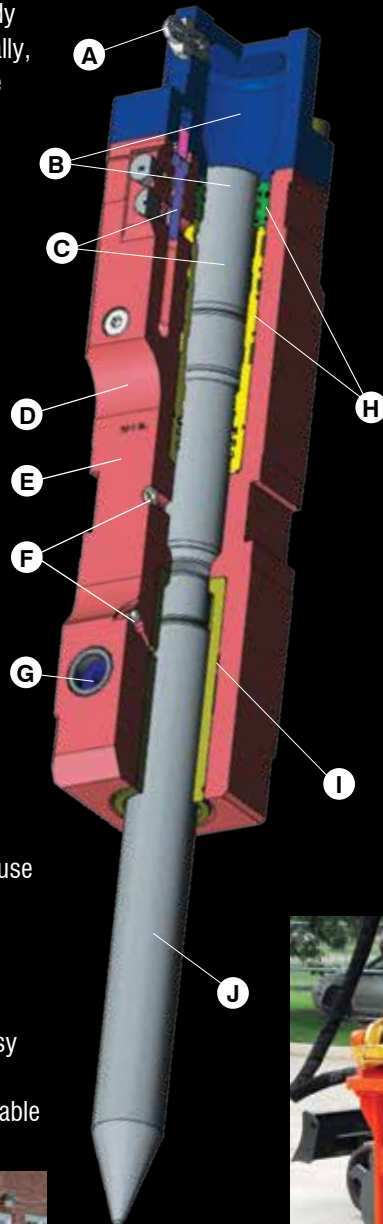

Medium to Large Hammer Lineup – GH Series

NPK's GH series hydraulic hammers feature our direct acting gas-charged piston creating maximum impact per blow. Our long stroke piston design, coupled with our shock absorbing rubber mounts, reduces recoil to the operator while increasing the life of the carrier. NPK's ABF feature allows the hammer to fire only when pressure is applied to the tool, increasing component life. These rugged hammers are capable of high production rates in all forms of concrete as well as both medium and hard rock. The simplicity of our hammer design is not limited to the main components. The standard bracket style makes servicing your NPK hammer simple. While lying horizontally, the hammer body can be removed without having to remove the top bracket.

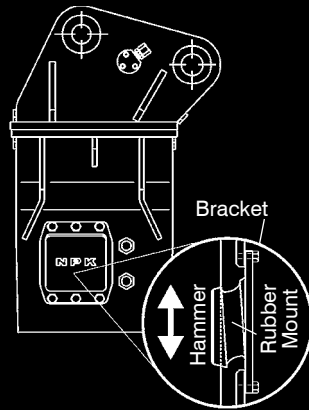

GH-Series Hammers

- A. Excellent power-to-weight ratio
- B. Unique gas-charged piston maximizes hammer efficiency
- C. Simple, two-moving-parts design for reliability
- D. Anti-blank fire feature for long hammer life
- E. Ports for automatic bushing lubrication and air for underwater use
- F. Bottom tie rod nuts for easier serviceability
- G. Quick-change tool system with single round retainer pin
- H. Variety of tool configurations available
- I. Replaceable cylinder sleeves for easy, economical rebuild
- J. Upper and lower replaceable tool bushings

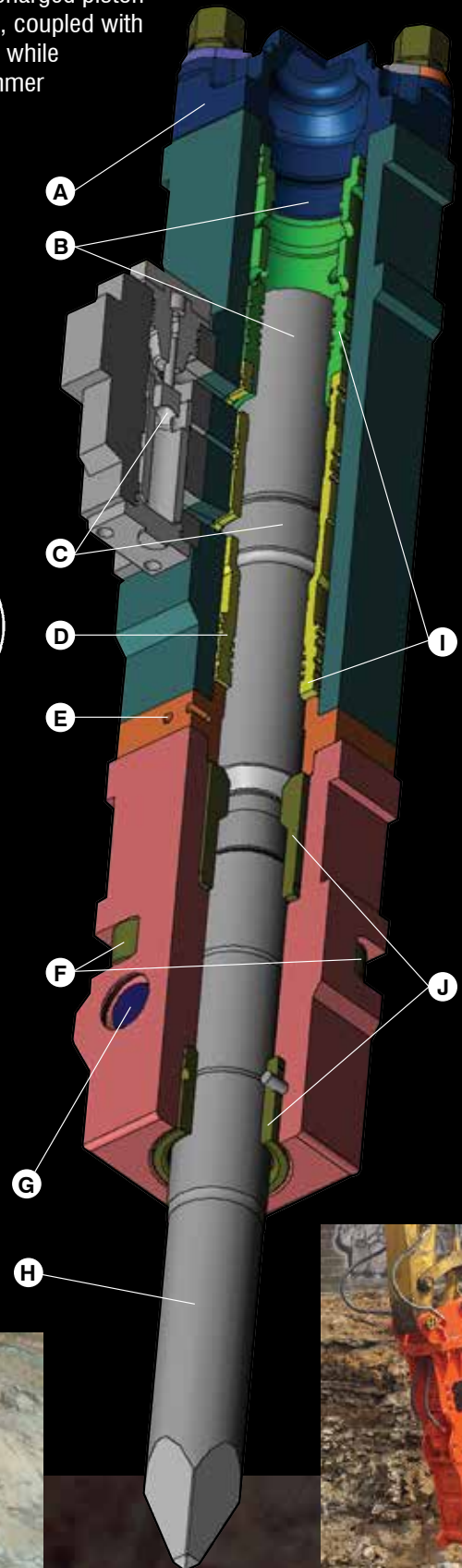

Standard & Specialty Tools

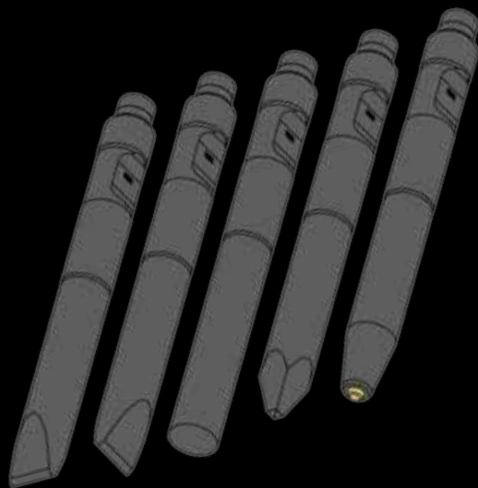

- **Chisel (FX) or (FY)**
Controlled breakage of concrete, layered sedimentary rock (trenching, breaking oversize), general demolition
- **Blunt Tool (E)**
Concrete slab, bridge decking, breaking oversize, slag removal
- **Moil Point (P)**
Soft material, breaking concrete structures - columns, etc., highway construction, general demolition
- **Core Tool (PC)**
Carbide steel core minimizes wear and breakage. Hard rock, general demolition. For GH-6 and larger

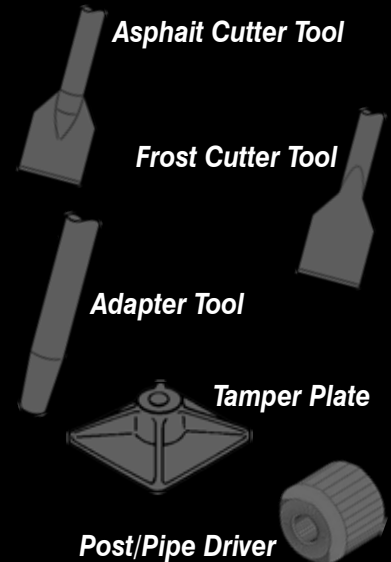

Quick Disconnects

NPK Quick Disconnects make hooking up your NPK C&D attachment a breeze! Quick disconnects are not only compatible with hammers, they can also be used with compactors, crushers, processors and more! With the addition of a quick disconnect package to each unit, you can easily swap out multiple NPK attachments onto a single carrier. When the disconnect is assembled and the female coupling nut is tightened the internal poppets are held rigid. Rapid pulsations or flow changes do not move internal parts, typically the source of deterioration in conventional designs. These internal poppets are guided by a long spool section, rather than the usual flimsy supports of lock rings and poppet guides. Also missing are any ball bearings, commonly the cause of failure in high pulsation environments. The generous flow path allows for very low pressure drops, which is revolutionary in coupling design.

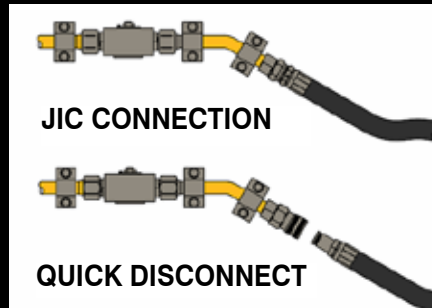

Dedicated Mounting Brackets

- **Bracket weldment that conforms to the exact dimensional hook-up of your carrier**
 - Mini excavators
 - Skid steers
 - Backhoes
 - Wheel loaders
 - Full size excavators
- **Whip hoses included**
- **Mounting pins available**



Hammer Mounted Auto Lubes

- Increase Hammer Versatility
- Reduce Maintenance Cost
- Greater Productivity
- Hydraulically Driven, Automatically Providing a Continuous Supply of Grease while Hammer is Running
- Reliable Even in Low Temperatures
- Suitable for Special Lubricants Including Copper Based Pastes
- All NPK Auto Lube Systems Include Mounting Hardware and Adapter Fittings
- Various Cartridge Adapters Available for Conforming to Different Size Grease Tubes
- Cartridge Refill Adapter Provided with Pump for Refilling Grease Tubes



G015: Compatible with PH-3, PH-4, GH-6



G025: Compatible with GH-7, GH-9, GH-10, GH-12, GH-15, GH-18, GH-23, GH-30, GH-40

Carrier Mounted Auto Lubes

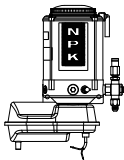
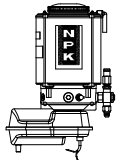
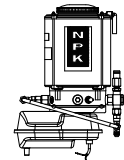
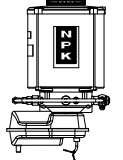
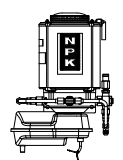
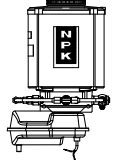
	G-075/G-075L	G-100/G-100L	G-150/G-150L	G-153/G-153L	G-175/G-175L	G-186/G-186L
						
Reservoir Capacity	4.4 lbs.	8.8 lbs.	8.8 lbs.	17.6 lbs.	8.8 lbs.	17.6 lbs.
Maximum Output/Hr	1/2 lb.	1/2 lb.	1 lb.	1 1/2 lbs.	1 1/2 lbs.	1 1/2 lbs.
Models	PH-3, PH-4	GH-6, GH-7, GH-9	GH-10, GH-12, GH-15, GH-18, GH-23	GH-30, GH-40, GH-50		

L Models come with a low level switch that activates a warning light and buzzer in the cab, and can be wired (on solenoid energized circuits) to shut off hammer when insufficient grease levels are detected.

It is imperative that special lubricants be used in your NPK hammer to protect the main components. NPK grease products contain additives that resist extreme pressures and heat. Our specially formulated moly based grease and chisel paste are available through your local NPK dealer. NPK lubricants are offered in 14oz. cartridges, 35lb. pails, 120lb. kegs, 400lb. drums, or refillable cartridges for hammer mounted auto lube systems.



Dust Suppression

Available on PH-1, PH-2, PH-3, PH-4 with enclosed bracket

- Water Spray Nozzle Integrated into Bracket
- Wide Spray Angle for Maximum Coverage
- Easy Access for Serviceability
- Ready to be Connected to Water Supply

NPK's water-ready hammers help to make working environments safer and to meet OSHA silica dust reduction regulations.



HYDRAULIC HAMMERS

The right model for every machine

Specifications								
NPK Model	Impact Energy Class* ft lbs	Impact Frequency bpm	Recommended Carrier Weight tons	Oil Flow gpm (lpm)	Operating Pressure psi (bar)	Working Weight lb (kg)	Tool Diameter in (mm)	Tool Working Length in (mm)
PH-06	150	480-1200	1.2-2.2	4-9 (15-35)	2,030 (140)	220 (100)	1.7 (42)	11.8 (300)
PH-07	200	450-1300	1.5-2.75	4-12 (15-45)	2,465 (170)	275 (125)	1.9 (47)	12.4 (316)
PH-1	350	550-1100	2-3.5	7-15 (25-55)	2,465 (170)	500 (225)	2.2 (57)	14 (356)
PH-2	500	500-1200	3-5.5	7-16 (25-60)	2,465 (170)	610 (275)	2.6 (66)	15.1 (384)
PH-3	750	500-1150	4-8	12-26 (45-100)	2,465 (170)	990 (450)	3.0 (76)	16.5 (419)
PH-4	1,300	400-1000	6-9	13-32 (50-120)	2,465 (170)	1,235 (560)	3.4 (86)	18.5 (469)
GH-6	2,000	500-800	11-15.5	24-40 (90-150)	2,400 (165)	2,500 (1,135)	4.2 (106)	19.7 (500)
GH-7	2,500	400-750	14-21	26-48 (100-180)	2,600 (180)	2,730 (1,240)	4.6 (116)	23 (583)
GH-9	3,000	500-670	20-28	40-53 (150-200)	2,600 (180)	3,420 (1,550)	5.0 (126)	23.9 (608)
GH-10	4,000	400-550	23-33	44-55 (165-210)	2,600 (180)	4,690 (2,125)	5.4 (136)	24.4 (620)
GH-12	5,500	380-480	28-43	45-58 (170-220)	2,650 (183)	6,135 (2,785)	5.7 (146)	25.6 (650)
GH-15	8,000	320-400	33-50	53-66 (200-250)	2,600 (180)	7,300 (3,310)	6.1 (156)	27.2 (690)
GH-18	12,000	300-400	35-57	58-77 (220-290)	2,500 (172)	8,470 (3,840)	6.5 (165)	29.1 (740)
GH-23	13,500	300-400	50-75	66-85 (250-320)	2,600 (180)	13,295 (6,030)	6.9 (174)	34.6 (880)
GH-30	15,000	310-390	50-93	74-92 (280-350)	2,600 (180)	15,665 (7,105)	7.2 (184)	32 (813)
GH-40	17,000	240-330	80-130	79-106 (300-400)	2,600 (180)	18,850 (8,550)	8.0 (204)	35.4 (899)
GH-50	20,000	210-280	120+	92-119 (350-450)	2,600 (180)	25,070 (11,370)	8.4 (214)	39.7 (1008)

* "Impact Energy Class" is a marketing rating and does not relate to measured impact energy. Working weights include tool and mounting bracket. Weights may vary depending on bracket configurations. Specifications subject to change without notice.

NPK...All the Right Attachments! With innovation throughout construction's most extensive line.



Compactor/Drivers



Concrete Crushers



Material Processors



Demolition Shears



Demolition Grabs



Sheet Pile Drivers



Pedestal Breaker Systems



NPK Construction Equipment, Inc.
 7550 Independence Drive
 Walton Hills, OH 44146-5541
 Phone (440) 232-7900
 Toll-free (800) 225-4379
 Fax (440) 232-4382
 Internet: www.npkce.com

Sold and Serviced by:

Each product sold by NPK is subject to an express written warranty. NPK makes no other warranty, express or implied, including any warranty of merchantability or fitness for any particular purpose. NPK is not liable for any incidental or consequential damages.